



**A PROJECT MANAGER'S**  
**BOOK OF**  
**FORMS**

A COMPANION TO THE  
*PMBOK® GUIDE - FIFTH EDITION*

*Includes online access to 650 updated  
forms for your use and customization*

**CYNTHIA STACKPOLE SNYDER**

 **WILEY**

 **PMI**  
Project Management Institute



# A PROJECT MANAGER'S BOOK OF FORMS

**Second Edition**



# A PROJECT MANAGER'S BOOK OF FORMS

**Second Edition**

**A Companion to the *PMBOK*<sup>®</sup> *Guide*,  
Fifth Edition**

**Cynthia Stackpole Snyder**

**WILEY**



Cover Design: John Wiley & Sons, Inc.  
Cover Illustration: © Sashkinw/iStockphoto

This book is printed on acid-free paper.

Copyright © 2013 by John Wiley & Sons, Inc. All rights reserved

Published by John Wiley & Sons, Inc., Hoboken, New Jersey  
Published simultaneously in Canada

No part of this publication may be reproduced, stored in a retrieval system, or transmitted in any form or by any means, electronic, mechanical, photocopying, recording, scanning, or otherwise, except as permitted under Section 107 or 108 of the 1976 United States Copyright Act, without either the prior written permission of the Publisher, or authorization through payment of the appropriate per-copy fee to the Copyright Clearance Center, 222 Rosewood Drive, Danvers, MA 01923, (978) 750-8400, fax (978) 646-8600, or on the web at [www.copyright.com](http://www.copyright.com). Requests to the Publisher for permission should be addressed to the Permissions Department, John Wiley & Sons, Inc., 111 River Street, Hoboken, NJ 07030, (201) 748-6011, fax (201) 748-6008, or online at [www.wiley.com/go/permissions](http://www.wiley.com/go/permissions).

**Limit of Liability/Disclaimer of Warranty:** While the publisher and author have used their best efforts in preparing this book, they make no representations or warranties with the respect to the accuracy or completeness of the contents of this book and specifically disclaim any implied warranties of merchantability or fitness for a particular purpose. No warranty may be created or extended by sales representatives or written sales materials. The advice and strategies contained herein may not be suitable for your situation. You should consult with a professional where appropriate. Neither the publisher nor the author shall be liable for damages arising herefrom.

For general information about our other products and services, please contact our Customer Care Department within the United States at (800) 762-2974, outside the United States at (317) 572-3993 or fax (317) 572-4002.

Wiley publishes in a variety of print and electronic formats and by print-on-demand. Some material included with standard print versions of this book may not be included in e-books or in print-on-demand. If this book refers to media such as a CD or DVD that is not included in the version you purchased, you may download this material at <http://booksupport.wiley.com>. For more information about Wiley products, visit [www.wiley.com](http://www.wiley.com).

Project Management Institute ([www.pmi.org](http://www.pmi.org)) is the leading advocate for the project management profession globally. Founded in 1969, PMI has more than 650,000 members and credential holders in 185 countries. PMI's Project Management Professional (PMP) credential is globally recognized as the gold standard credential in project management.

© 2013 Project Management Institute, Inc. All rights reserved.

“PMI,” the PMI logo, “PMP,” and “PMBOK” are registered marks of the Project Management Institute, Inc. For a comprehensive list of PMI marks, contact the PMI legal Department.

Library of Congress Cataloging-in-Publication Data available on request

ISBN: 978-1-118-43078-1; 978-111-8-53740-4 (ebk.); 978-111-8-53743-5 (ebk.); 978-111-8-53752-7 (ebk.)

Printed in the United States of America

10 9 8 7 6 5 4 3 2 1

# Contents

<b>Acknowledgments</b>	<b>vii</b>	2.19 Project Schedule / 65
<b>Introduction</b>	<b>ix</b>	2.20 Cost Management Plan / 68
<b>1 Initiating Forms</b>	<b>1</b>	2.21 Activity Cost Estimates / 71
1.0 Initiating Process Group / 1		2.22 Cost Estimating Worksheet / 73
1.1 Project Charter / 2		2.23 Cost Baseline / 78
1.2 Stakeholder Register / 8		2.24 Quality Management Plan / 80
1.3 Stakeholder Analysis Matrix / 11		2.25 Quality Metrics / 83
<b>2 Planning Forms</b>	<b>13</b>	2.26 Process Improvement Plan / 85
2.0 Planning Process Group / 13		2.27 Responsibility Assignment Matrix / 91
2.1 Project Management Plan / 16		2.28 Roles and Responsibilities / 93
2.2 Scope Management Plan / 20		2.29 Human Resource Management Plan / 96
2.3 Requirements Management Plan / 23		2.30 Communications Management Plan / 100
2.4 Requirements Documentation / 27		2.31 Risk Management Plan / 102
2.5 Requirements Traceability Matrix / 29		2.32 Risk Register / 109
2.6 Project Scope Statement / 33		2.33 Probability and Impact Assessment / 112
2.7 Assumption and Constraint Log / 36		2.34 Probability and Impact Matrix / 117
2.8 Work Breakdown Structure / 38		2.35 Risk Data Sheet / 119
2.9 WBS Dictionary / 40		2.36 Procurement Management Plan / 122
2.10 Schedule Management Plan / 43		2.37 Source Selection Criteria / 127
2.11 Activity List / 46		2.38 Stakeholder Management Plan / 129
2.12 Activity Attributes / 48		2.39 Change Management Plan / 132
2.13 Milestone List / 51		<b>3 Executing Forms</b>
2.14 Network Diagram / 53		
2.15 Activity Resource Requirements / 55		3.0 Executing Process Group / 135
2.16 Resource Breakdown Structure / 57		3.1 Team Member Status Report / 137
2.17 Activity Duration Estimates / 59		3.2 Change Request / 143
2.18 Duration Estimating Worksheet / 61		3.3 Change Log / 148

vi Contents

3.4	Decision Log /	150		
3.5	Quality Audit /	152		
3.6	Team Directory /	155		
3.7	Team Operating Agreement /	157		
3.8	Team Performance Assessment /	160		
3.9	Team Member Performance Assessment /	165		
3.10	Issue Log /	170		
<b>4</b>	<b>Monitoring and Control Forms</b>	<b>173</b>		
4.0	Monitoring and Controlling Process Group /	173		
4.1	Project Performance Report /	175		
4.2	Variance Analysis /	181		
4.3	Earned Value Status /	185		
4.4	Risk Audit /	188		
4.5	Contractor Status Report /	192		
4.6	Formal Acceptance /	196		
<b>5</b>	<b>Closing</b>		<b>199</b>	
5.0	Closing Process Group /	199		
5.1	Procurement Audit /	199		
5.2	Contract Close-Out /	203		
5.3	Project or Phase Close-Out /	207		
5.4	Lessons Learned /	211		



# Acknowledgments

First and foremost, thank you to my husband Dexter Dionisio for helping me with the forms in this second edition. I know it was a thankless and tedious job and I so appreciate your help. Your support for me in all my writing efforts means so much to me.

I would also like to thank members of the core committee from the *PMBOK® Guide—Fifth Edition* for reviewing all the descriptions to make sure they are aligned with the latest edition of the standard for project management. In particular, a big thank you to Dave Violette, Project Chair for the development of the *PMBOK® Guide—Fifth Edition*, Marie Gunnerson, George Jucan, Theofanis C. Giotis, Mercedes Martinez Sanz, and Nick Clemens.

Thank you to Amanda Miller and Bob Argentieri for bringing me out to lovely Hoboken to strategize the new approach for this second edition of the *Book of Forms*. I think our brainstorming efforts paid off. I think the look, feel and usability of the second edition is better than the first.

Thank you again to Dan Magers, Amy Odum and Kerstin Nasdeo for your efforts in organizing all the post-writing work to get everything organized, laid out, and through production. I always appreciate your professionalism.

I appreciate Donn Greenburg, Barbara Walsh, Amy Goretzky, and Roberta Storer for the work you all do to support this book and the other publications we work on. I am looking forward to the electronic spinoffs for the forms and I appreciate your support with that project!

A special shout out to Bisk Education, Villanova faculty, Chuck Arnao, and all the Villanova students who use this book. Thank you for purchasing and using this book. I hope it helps you!



# Introduction

This second edition of the *Project Management Book of Forms* is designed to be a companion to the Fifth Edition of *A Guide to the Project Management Body of Knowledge (PMBOK® Guide)*. The purpose is to present the information from the *PMBOK® Guide—Fifth Edition* in a set of forms and reports so that project managers can readily apply the concepts and practices described in the *PMBOK® Guide* to their projects.

The *PMBOK® Guide* identifies that subset of the project management body of knowledge generally recognized as good practice. As an ANSI Standard, it does not describe how to apply those practices, nor does it provide a vehicle for transferring that knowledge into practice.

This *Book of Forms* will assist project managers in applying information presented in the *PMBOK® Guide* into project documentation. The *Book of Forms* does not teach project management concepts or describe how to apply project management techniques. Textbooks and classes can fulfill those needs. This book provides an easy way to apply good practices to projects.

Since one of the defining factors about projects is that they are unique, project managers must tailor the forms and reports to meet the needs of their individual projects. Some projects will require information in addition to what is presented in these forms; some will require less. These forms are presented in paper format and electronic versions to make them easy to adapt to the needs of specific projects. They follow the information in the *PMBOK® Guide* but can be adapted to meet the needs of the project manager and specific projects.

## AUDIENCE

This book is written specifically for project managers to help manage all aspects of the project. Those new to project management can use the forms as a guide in collecting and organizing project information. Experienced project managers can use the forms as a template so that they collect a set of consistent data on all projects. In essence, the forms save reinventing the wheel for each project.

A secondary audience is the manager of project managers or a project management office. Using the information in this book ensures a consistent approach to project documentation. Adopting these forms on an organizational level will enable a repeatable approach to project management.

## ORGANIZATION

The forms are organized by process group: initiating, planning, executing, monitoring and controlling, and closing. Within those process groups, the forms are arranged sequentially as presented in the *PMBOK® Guide—Fifth Edition*.

A description of each form is presented along with a list of contents and a brief explanation of the type of information that goes in each field. For the planning forms, there is a description of where the information in the form comes from (inputs) and where it goes (outputs). For some forms, there is a list of related forms. Following the description, a blank copy of the form is presented. Electronic versions of the forms are available at [www.wiley.com/go/bookofforms2e](http://www.wiley.com/go/bookofforms2e); all are in Microsoft® Office software for ease of tailoring.

There are a few forms included that are not mentioned in the *PMBOK® Guide—Fifth Edition*. These are forms that assist in managing a project but are not considered part of the project management standard.

There have been some requests for completed samples of each form. Due to the unique nature of projects and because this book is meant to span all industries and be used by a wide audience it is not practical to provide examples of completed forms. However, in this current edition we have included a table with a description of the information that would go in each field, and in some instances provided examples for clarification.

Not all forms will be needed on all projects. Use the forms you need, to the degree that you need them, to assist you in managing your projects.



# Initiating Forms

## 1.0 INITIATING PROCESS GROUP

The purpose of the initiating process group is to authorize a project, provide a high-level definition of the project, and identify stakeholders. There are two processes in the initiating process group:

- Develop Project Charter
- Identify Stakeholders

The intent of the initiating process group is to at least:

- Authorize a project
- Identify project objectives
- Define the initial scope of the project
- Obtain organizational commitment
- Assign a project manager
- Identify project stakeholders

As the first processes in the project, the initiating processes are vital to starting a project effectively. These processes can be revisited throughout the project for validation and elaboration as needed.

The forms used to document initiating information include:

- Project Charter
- Stakeholder Register
- Stakeholder Analysis Matrix

These forms are consistent with the information in the *PMBOK® Guide*—Fifth Edition. Tailor them to meet the needs of your project by editing, combining, or revising them.

## 2 Initiating Forms

### 1.1 PROJECT CHARTER

The project charter is a document that formally authorizes a project or phase. The project charter defines the reason for the project and assigns a project manager and his or her authority level for the project. The contents of the charter describe the project in high-level terms, such as:

- Project purpose or justification
- High-level project description
- High-level requirements
- Project objectives and related success criteria
- High-level risks
- Summary milestone schedule
- Summary budget
- Stakeholder list
- Project approval requirements
- Assigned project manager, responsibility, and authority level
- Name and authority of the sponsor or other person(s) authorizing the project charter

Use the information from your project to tailor the form to best meet your needs.

The project charter can receive information from:

- Agreements (contracts)
- Statements of work
- Business case

It provides information to:

- Stakeholder Register
- Project Management Plan
- Scope Management Plan
- Project Scope Statement
- Requirements Documentation
- Requirements Management Plan
- Requirements Traceability Matrix
- Schedule Management Plan
- Cost Management Plan
- Risk Management Plan

The project charter is an output from the process 4.1 Develop Project Charter in the *PMBOK® Guide*—Fifth Edition. You can use the element descriptions in Table 1.1 to assist you in developing a project charter.

**TABLE 1.1 Elements of a Project Charter**

Document Element	Description
Project purpose or justification	The reason the project is being undertaken. May refer to a business case, the organization's strategic plan, external factors, a contract agreement, or any other reason for performing the project.
High-level project description	A summary-level description of the project. May include information on high-level product and project deliverables as well as the approach to the project.

Document Element	Description
High-level requirements	The high-level conditions or capabilities that must be met to satisfy the purpose of the project. Describe the product features and functions that must be present to meet stakeholders' needs and expectations. This section does not describe the detailed requirements as those are covered in requirements documentation.
Project objectives and related success criteria	<p>Project objectives are usually established for at least scope, schedule, and cost.</p> <p>Scope objectives describe the scope needed to achieve the planned benefits of the project. An example you could use for a fundraising 10K run is "The event will provide a 6.2 mile course, and raise \$1.2 million for the specified charity."</p> <p>Success criteria is the course that is certified as a 10K course and over \$1.2 million in collected pledges.</p> <p>Time objectives describe the goals for the timely completion of the project. For example, the run will take place in September of the current year. The success criteria is whether or not the run took place in September.</p> <p>Cost objectives describe the goals for project expenditures. An example is: "The cost for producing the run will not exceed \$100,000." Obviously the success criteria is determined by the total amount spent producing the event.</p> <p>There may be additional objectives as well. Some organizations include quality objectives, safety objectives, and stakeholder satisfaction objectives.</p>
High-level risks	The initial risks at a project level, such as funding availability, new technology, or lack of resources.
Summary milestone schedule	Significant events in the project. Examples include the completion of key deliverables, the beginning or completion of a project phase, or product acceptance.
Summary budget	The estimated range of expenditures for the project.
Stakeholder list	A list of people who have an interest and an influence on the project success.
Project approval requirements	The criteria that must be met for the project to be accepted by the customer or sponsor.
Assigned project manager, responsibility, and authority level	<p>The authority of the project manager with regard to staffing, budget management and variance, technical decisions, and conflict resolution.</p> <p>Examples of staffing authority include the power to hire, fire, discipline, and accept or not accept project staff.</p> <p>Budget management refers to the ability of the project manager to commit, manage, and control project funds. Variance refers to the variance levels that require escalation for approval or re-baselining.</p> <p>Technical decisions define or limit the authority of the project manager to make technical decisions about deliverables or the project approach.</p> <p>Conflict resolution defines the degree to which the project manager can resolve conflict within the team, within the organization, and with external stakeholders.</p>
Name and authority of the sponsor or other person(s) authorizing the project charter	The name, position, and authority of the person who oversees the project manager for the purposes of the project. Common types of authority include the ability to approve changes, determine acceptable variance limits, impact inter-project conflicts, and champion the project at a senior management level.

# PROJECT CHARTER

Project Title: \_\_\_\_\_

Project Sponsor: \_\_\_\_\_ Date Prepared: \_\_\_\_\_

Project Manager: \_\_\_\_\_ Project Customer: \_\_\_\_\_

Project Purpose or Justification:

Project Description:

High-Level Requirements:

High-Level Risks:



# PROJECT CHARTER

<b>Project Objectives</b>	<b>Success Criteria</b>	<b>Person Approving</b>
---------------------------	-------------------------	-------------------------

**Scope:**

--	--	--

**Time:**

--	--	--

**Cost:**

--	--	--

**Other:**

--	--	--

Summary Milestones	Due Date

# PROJECT CHARTER

Estimated Budget:

--

Stakeholder(s)	Role

Project Manager Authority Level

Staffing Decisions:

--

Budget Management and Variance:

--

# PROJECT CHARTER

Technical Decisions:

Conflict Resolution:

Approvals:

\_\_\_\_\_  
Project Manager Signature

\_\_\_\_\_  
Sponsor or Originator Signature

\_\_\_\_\_  
Project Manager Name

\_\_\_\_\_  
Sponsor or Originator Name

\_\_\_\_\_  
Date

\_\_\_\_\_  
Date

## 8 Initiating Forms

### 1.2 STAKEHOLDER REGISTER

The Stakeholder Register is used to identify those people and organizations impacted by the project and document relevant information about each stakeholder. Relevant information can include:

- Name
- Position in the organization
- Role in the project
- Contact information
- List of stakeholder's major requirements
- List of stakeholder's expectations
- Potential influence on the project
- A classification or categorization of each stakeholder

The Stakeholder Register is a dynamic project document. The stakeholders, their level of influence, requirements, and classification are likely to change throughout the project. Initially you will not have enough information to complete the register. As the project gets underway you will gain additional information and understanding about each stakeholder's requirements, expectations, and influence and the Stakeholder Register will become more robust.

Information in the Stakeholder Register should be tailored to meet the needs of the project. For example, some projects may have internal and external stakeholders while others may only have internal stakeholders. The following sample is just one approach to identifying and documenting stakeholder information.

The Stakeholder Register receives information from:

- Project charter
- Procurement documents

It is related to:

- Stakeholder Analysis Matrix

It provides information to:

- Requirements Documentation
- Quality Management Plan
- Communications Management Plan
- Risk Management Plan
- Risk Register
- Stakeholder Management Plan

The Stakeholder Register is an output from the process 13.1 Identify Stakeholders in the *PMBOK® Guide—Fifth Edition*

You can use the element descriptions in Table 1.2 to assist you in developing a Stakeholder Register.

**TABLE 1.2 Elements of a Stakeholder Register**

<b>Document Element</b>	<b>Description</b>
Name	Stakeholder's name. If you don't have a name you can substitute a position or organization until you have more information.
Position	The position the stakeholder holds in the organization or enterprise, for example, programmer, human resources analyst, or quality assurance specialist.
Role	The function the stakeholder performs on the project team, such as testing lead, scrum master, or scheduler.
Contact information	How to communicate with the stakeholder, such as their phone number, email address, or physical address.
Requirements	High-level needs for the project and/or product.
Expectations	Main expectations of the project and/or product.
Influence	The degree of influence the stakeholder has on the project. This can be a narrative description or high, medium, or low influence.
Classification	Some projects may categorize stakeholders as friend, foe, or neutral; others may classify them as high, medium, or low impact.

# STAKEHOLDER REGISTER

Project Title: \_\_\_\_\_ Date Prepared: \_\_\_\_\_

Name	Position	Role	Contact Information	Requirements	Expectations	Influence	Classification

### 1.3 STAKEHOLDER ANALYSIS MATRIX

The Stakeholder Analysis Matrix is used to classify stakeholders. It can be used to help fill in the Stakeholder Register. The classifications of stakeholders can also be used to plan stakeholder engagement for groups of stakeholders.

The following example is used to assess the relative power (high or low) on one axis and the relative interest (high or low) on the other axis. There are many other ways to categorize stakeholders using a grid. Some examples include:

- Influence/impact
- Friend/foe

The needs of the project will determine if a Stakeholder Analysis Matrix will be helpful and, if so, what stakeholder aspects should be assessed. Use the information from your project to tailor the form to best meet your needs.

The Stakeholder Analysis Matrix receives information from:

- Project charter
- Procurement documents

It is related to:

- Stakeholder Register

The Stakeholder Analysis Matrix is a tool used in 13.1 Identify Stakeholders in the *PMBOK® Guide—Fifth Edition*.

# STAKEHOLDER ANALYSIS MATRIX

Project Title: \_\_\_\_\_

Date Prepared: \_\_\_\_\_

Power

Interest



# Planning Forms

## 2.0 PLANNING PROCESS GROUP

The purpose of the planning process group is to elaborate the information from the project charter to create a comprehensive set of plans that will enable the project team to deliver the project objectives. There are 24 processes in the planning process group.

- Develop Project Management Plan
- Plan Scope Management
- Collect Requirements
- Define Scope
- Create WBS
- Plan Schedule Management
- Define Activities
- Sequence Activities
- Estimate Activity Resources
- Estimate Activity Durations
- Develop Schedule
- Plan Cost Management
- Estimate Costs
- Determine Budget
- Plan Quality Management
- Plan Human Resource Management
- Plan Communications Management
- Plan Risk Management
- Identify Risks
- Perform Qualitative Analysis
- Perform Quantitative Analysis
- Plan Risk Responses
- Plan Procurement Management
- Plan Stakeholder Management

The intent of the planning process group is to at least:

- Elaborate and clarify the project scope
- Develop a realistic schedule

## 14 Planning Forms

- Develop a realistic budget
- Identify project and product quality processes
- Plan the human resource aspects of the project
- Determine the communication needs
- Establish risk management practices
- Identify the procurement needs of the project
- Determine how to manage stakeholder engagement
- Combine all the planning information into a project management plan and a set of project documents that are cohesive and integrated

Planning is not a one-time event. It occurs throughout the project. Initial plans will become more detailed as additional information about the project becomes available. Additionally, as changes are approved for the project or product, many of the planning processes will need to be revisited and the documents revised and updated.

Many of the forms in this section provide information needed for other forms. The form description indicates from where information is received and to where it goes.

The forms used to document planning information include:

- Project Management Plan
- Scope Management Plan
- Requirements Management Plan
- Requirements Documentation
- Requirements Traceability Matrix
- Project Scope Statement
- Assumption and Constraint Log
- Work Breakdown Structure
- Work Breakdown Structure Dictionary
- Schedule Management Plan
- Activity List
- Activity Attributes
- Milestone List
- Network Diagram
- Activity Resource Requirements
- Resource Breakdown Structure
- Activity Duration Estimates
- Duration Estimating Worksheet
- Project Schedule
- Cost Management Plan
- Activity Cost Estimates
- Cost Estimating Worksheet
- Bottom-Up Cost Estimating Worksheet
- Cost Baseline
- Quality Management Plan
- Quality Metrics
- Process Improvement Plan
- Responsibility Assignment Matrix
- Roles and Responsibilities
- Human Resource Management Plan
- Communications Management Plan
- Risk Management Plan
- Risk Register
- Probability and Impact Assessment

- Probability and Impact Matrix
- Risk Data Sheet
- Procurement Management Plan
- Source Selection Criteria
- Change Management Plan
- Stakeholder Management Plan

Some forms in this section are not explicitly described in the *PMBOK® Guide*, but they are useful in planning and managing a project. Use the forms here as a starting point for your project. You should tailor the forms to meet the needs of your project by editing, combining, or revising them.

## 2.1 PROJECT MANAGEMENT PLAN

The project management plan describes how the team will execute, monitor, control, and close the project. While it has some unique information, it is primarily comprised of all the subsidiary management plans and the baselines. The project management plan combines all this information into a cohesive and integrated approach to managing the project. Typical information includes:

- Selected project life cycle
- Processes used to manage the project and information on how they have been tailored
- Tools and techniques that will be used in the project management processes
- Specific approaches to meet project objectives
- Variance thresholds
- Baseline management
- Timing and types of reviews

The project management plan contains plans for managing all the other knowledge areas as well as other specific aspects of the project. These take the form of subsidiary management plans and can include:

- Scope Management Plan
- Schedule Management Plan
- Requirements Management Plan
- Cost Management Plan
- Quality Management Plan
- Human Resources Management Plan
- Communications Management Plan
- Risk Management Plan
- Procurement Management Plan
- Stakeholder Management Plan
- Change Management Plan
- Configuration Management Plan
- Process Improvement Plan

The project management plan also contains baselines. Common baselines include:

- Scope baseline
- Schedule baseline
- Cost baseline

In addition, any other relevant, project-specific information that will be used to manage the project is recorded in the project management plan.

The project management plan can receive information from all the subsidiary management plans and baselines. Because it is the foundational document for managing the project it also provides information to all subsidiary plans. In addition, the project management plan provides information to all other integration processes and the work performance information from all the control processes.

You can use the element descriptions in Table 2.1 to assist you in developing a project management plan.

**TABLE 2.1 Elements of a Project Management Plan**

Document Element	Description
Project life cycle	Describe the life cycle that will be used to accomplish the project. This may include phases and deliverables for each phase.
Project management processes and tailoring decisions	Indicate any decisions made to combine, omit, or expand project management processes. This may include defining the specific processes used in each life cycle phase and whether it is a summary or detailed application of specific processes.
Process tools and techniques	Identify the specific tools and techniques you will be using for the various processes. For example, if you are using a specific cost estimating software or a particular quality control technique.
Project approaches	Document the specific approach you will take to accomplish the project. This may include specific information about stakeholder engagement, product development, system integration, or any other aspects of the project approach.
Schedule variance threshold	Define acceptable schedule variances, variances that indicate a warning, and variances that are unacceptable. Schedule variances may indicate the percent of variance from the baseline or they may include the amount of float used or whether any schedule reserve has been used.
Schedule baseline management	Describe how the schedule baseline will be managed, including responses to acceptable, warning, and unacceptable variances. Define circumstances that would trigger preventive or corrective action and when the change control process would be enacted.
Cost variance threshold	Define acceptable cost variances, variances that indicate a warning, and variances that are unacceptable. Cost variances may indicate the percent of variance from the baseline, such as 0–5%, 5–10%, and greater than 10%.
Cost baseline management	Describe how the cost baseline will be managed, including responses to acceptable, warning, and unacceptable variances. Define circumstances that would trigger preventive or corrective action and when the change control process would be enacted.
Scope variance threshold	Define acceptable scope variances, variances that indicate a warning, and variances that are unacceptable. Scope variance can be indicated by the features and functions that are present in the end product, or the performance metrics that are desired.
Scope baseline management	Describe how the scope baseline will be managed, including responses to acceptable, warning, and unacceptable variances. Define circumstances that would trigger preventive or corrective action and when the change control process would be enacted. Define the difference between a scope revision and a scope change. Generally a revision does not require the same degree of approval that a change does. For example, changing the color of something is a revision, changing a function is a change.
Project reviews	List any project reviews, for example integrated baseline reviews, phase gate reviews, integration readiness reviews, quality reviews, etc.
Subsidiary management plans	Define the approach for each knowledge area in the project or refer to an attachment for a specific subsidiary management plan.
Baselines	Attach all project baselines.

# PROJECT MANAGEMENT PLAN

Project Title: \_\_\_\_\_ Date Prepared: \_\_\_\_\_

## Project Life Cycle

Phase	Key Deliverables

## Project Management Processes and Tailoring Decisions

Knowledge Area	Processes	Tailoring Decisions
Integration		
Scope		
Time		
Cost		
Quality		
Human Resources		
Communication		
Risk		
Procurement		
Stakeholders		

# PROJECT MANAGEMENT PLAN

## Process Tools and Techniques

Knowledge Area	Tools and Techniques
Integration	
Scope	
Time	
Cost	
Quality	
Human Resources	
Communication	
Risk	
Procurement	
Stakeholders	

## Variances and Baseline Management

Scope Variance	Scope Baseline Management
Schedule Variance	Schedule Baseline Management
Cost Variance	Cost Baseline Management

## Project Reviews

--

## 2.2 SCOPE MANAGEMENT PLAN

The Scope Management Plan is part of the project management plan. It specifies how the project scope will be defined, developed, monitored, controlled, and validated. Planning how to manage scope should include at least processes for:

- Developing a detailed scope statement
- Decomposing the project into discrete deliverables using a WBS
- Determining what constitutes a scope change versus a revision and how scope changes will be managed through the formal change control process
- Maintaining the WBS and the scope baseline
- How deliverables will be accepted

In addition, the Scope Management Plan may provide direction on the elements that should be contained in a WBS Dictionary and how the scope and requirements management plans interact.

The Scope Management Plan can receive information from:

- Project Charter
- Project Management Plan

It is related to:

- Requirements Management Plan

It provides information to:

- Requirements Documentation
- Scope Statement
- WBS
- WBS Dictionary

The Scope Management Plan is an output from the process 5.1 Plan Scope Management in the *PMBOK® Guide—Fifth Edition*.

You can use the element descriptions in Table 2.2 to assist you in developing a Scope Management Plan.

**TABLE 2.2 Elements of the Scope Management Plan**

Document Element	Description
Scope Statement development	Describe how the Scope Statement will be developed including any alternatives analysis, stakeholder interviews, or research that will be conducted.
WBS structure	Describe the WBS structure and whether it will be arranged using phases, geography, major deliverables, or some other way. The guidelines for establishing control accounts and work packages may also be documented in this section.
WBS Dictionary	Identify the fields that will be used in the WBS Dictionary and the level of detail needed.
Scope baseline maintenance	Identify the types of scope changes that will need to go through the formal change control process and how the scope baseline will be maintained.
Scope change	Describe how changes to scope will be managed. This includes articulating the difference between a scope change and a scope revision.
Deliverable acceptance	For each deliverable identify how the deliverable will be validated for customer acceptance, including any tests or documentation needed for signoff.
Scope and requirements integration	Describe how project and product requirements will be addressed in the Project Scope Statement and WBS. Identify the integration points and how requirements and scope validation will take place.



# SCOPE MANAGEMENT PLAN

Project Title: \_\_\_\_\_ Date: \_\_\_\_\_

## Scope Statement Development

## WBS Structure

## WBS Dictionary

# SCOPE MANAGEMENT PLAN

## Scope Baseline Maintenance

## Scope Change

## Deliverable Acceptance

## Scope and Requirements Integration

## 2.3 REQUIREMENTS MANAGEMENT PLAN

The Requirements Management Plan is part of the project management plan. It specifies how requirements activities will be conducted throughout the project. Managing requirements activities includes at least:

- Planning activities such as:
  - Collecting
  - Analyzing
  - Categorizing
  - Prioritizing
  - Documenting
  - Determining metrics
  - Defining the traceability structure
- Managing activities such as:
  - Tracking
  - Reporting
  - Tracing
  - Validating
  - Performing configuration management

Use the information from your project to tailor the form to best meet your needs.

The Requirements Management Plan can receive information from:

- Project Charter
- Stakeholder Register

It is related to:

- Scope Management Plan

It provides information to:

- Requirements Documentation
- Requirements Traceability Matrix

The Requirements Management Plan is an output from the process 5.1 Plan Scope Management in the *PMBOK® Guide—Fifth Edition*.

You can use the element descriptions Table 2.3 to assist you in developing a Requirements Management Plan.

**TABLE 2.3 Elements of the Requirements Management Plan**

Document Element	Description
Requirements collection	Describe how requirements will be collected. Consider techniques such as brainstorming, interviewing, observation, etc.
Requirements analysis	Describe how requirements will be analyzed for prioritization, categorization, and impact to the product or project approach.
Requirements categories	Identify categories for requirements such as business, stakeholder, quality, etc.
Requirements documentation	Define how requirements will be documented. The format of requirements documentation may range from a simple spreadsheet to more elaborate forms containing detailed descriptions and attachments.
Requirements prioritization	Identify the prioritization approach for requirements. Certain requirements will be non-negotiable, such as those that are regulatory or those that are needed to comply with the organization’s policies or infrastructure. Other requirements may be nice to have, but not necessary for functionality.
Requirements metrics	Document the metrics that requirements will be measured against. For example, if the requirement is that the product must be able to support 150 lbs., the metric may be that it is designed to support 120% (180 lbs.) and that any design or engineering decisions that cause the product to go below the 120% need approval by the customer.
Requirements traceability structure	Identify the information that will be used to link requirements from their origin to the deliverables that satisfy them.
Requirements tracking	Describe how often and what techniques will be used to track progress on requirements.
Requirements reporting	Describe how reporting on requirements will be conducted and indicate the frequency.
Requirements validation	Identify the various methods that will be used to validate requirements such as inspection, audits, demonstration, testing, and so forth.
Requirements configuration management	Describe the configuration management system that will be used to control requirements, documentation, the change management process, and the authorization levels needed to approve changes.

# REQUIREMENTS MANAGEMENT PLAN

Project Title: \_\_\_\_\_ Date: \_\_\_\_\_

**Collection**

**Analysis**

**Categories**

**Documentation**

**Prioritization**

# REQUIREMENTS MANAGEMENT PLAN

## Metrics

## Traceability Structure

## Tracking

## Reporting

## Validation

## Configuration Management

## 2.4 REQUIREMENTS DOCUMENTATION

The project’s success is directly influenced by the discovery and decomposition of stakeholders’ needs into requirements and by the care taken in determining, documenting, and managing the requirements of the product, service, or result of the project.

These requirements need to be documented in enough detail to be included in the scope baseline and be measured and validated. Requirements documentation assists the project manager in making tradeoff decisions among requirements and in managing stakeholder expectations. Requirements will be progressively elaborated as more information about the project becomes available.

When documenting requirements, it useful to group them by category. Some common categories include:

- Business requirements
- Stakeholder requirements
- Solution requirements
- Transition requirements
- Project requirements
- Quality requirements

Other information about requirements may be documented, such as dependencies between requirements and assumptions and constraints pertaining to requirements.

Use the information from your project to tailor the form to best meet your needs.

Requirements Documentation can receive information from:

- Project Charter
- Stakeholder Register
- Scope Management Plan
- Requirements Management Plan
- Stakeholder Management Plan

It is related to:

- Requirements Traceability Matrix

It provides information to:

- Scope Baseline
- Quality Management Plan
- Procurement Management Plan

Requirements Documentation is an output from the process 5.2 Collect Requirements in the *PMBOK® Guide—Fifth Edition*.

You can use the element descriptions in Table 2.4 to assist you in developing Requirements Documentation.

**TABLE 2.4 Elements of Requirements Documentation**

Document Element	Description
Stakeholder	Stakeholder’s name. If you don’t have a name you can substitute a position or organization until you have more information.
Requirement	The condition or capability that must be met by the project or be present in the product, service, or result to satisfy a need or expectation of a stakeholder.
Category	The category of the requirement.
Priority	The priority group. For example Level 1, Level 2, etc., or must have, should have, or would be nice to have.
Acceptance criteria	The criteria that must be met for the stakeholder to approve that the requirement has been fulfilled.

# REQUIREMENTS DOCUMENTATION

Project Title: \_\_\_\_\_

Date Prepared: \_\_\_\_\_

ID	Requirement	Stakeholder	Category	Priority	Acceptance Criteria	Validation Method



## 2.5 REQUIREMENTS TRACEABILITY MATRIX

A Requirements Traceability Matrix is used to track the various attributes of requirements throughout the project life cycle. It uses information from the Requirements Documentation and traces how those requirements are addressed through other aspects of the project. The following form shows how requirements would be traced to project objectives, WBS deliverables, the metrics they will be measured to, and how they will be validated.

Another way to use the matrix is to trace the relationship between categories of requirements. For example:

- Functional requirements and technical requirements
- Security requirements and technical requirements
- Business requirements and technical requirements

An Inter-Requirements Traceability Matrix can be used to record this information. A sample form is included after the Requirements Traceability Matrix.

Use the information on your project to tailor the form to best meet your needs.

Requirements Traceability Matrix can receive information from:

- Scope Management Plan
- Requirements Management Plan
- Stakeholder Management Plan
- Project Charter
- Stakeholder Register

It is related to:

- Requirements Documentation

It provides information to:

- Product Acceptance
- Change Requests

Requirements Documentation is an output from the process 5.2 Collect Requirements in the *PMBOK® Guide—Fifth Edition*.

You can use the element descriptions in Table 2.5 and Table 2.6 to assist you in developing a Requirements Traceability Matrix and an Inter-Requirements Traceability Matrix.

**TABLE 2.5 Requirements Traceability Matrix**

Document Element	Description
ID	Enter a unique requirement identifier.
Requirement	Document the condition or capability that must be met by the project or be present in the product, service, or result to satisfy a need or expectation of a stakeholder.
Priority	Prioritize the requirement category. For example, Level 1, Level 2, etc., or must have, should have, or would be nice to have.
Category	Categorize the requirement. Categories can include functional, nonfunctional, maintainability, security, etc.
Source	Document the stakeholder who identified the requirement.
Project objective	List the project objective as identified in the Charter that is met by fulfilling the requirement.

*(continued)*

**TABLE 2.5 (continued)**

<b>Document Element</b>	<b>Description</b>
WBS Deliverable	Identify the WBS Deliverable that is associated with the requirement.
Metric	Describe the metric that is used to measure the satisfaction of the requirement.
Validation	Describe the technique that will be used to validate that the requirement meets the stakeholder needs.

**TABLE 2.6 Inter-Requirements Traceability Matrix**

<b>Document Element</b>	<b>Description</b>
ID	Enter a unique requirement identifier.
Business requirement	Document the business condition or capability that must be met by the project or be present in the product, service, or result to satisfy a need or expectation of a stakeholder.
Priority	Prioritize the requirement category. For example, Level 1, Level 2, etc., or must have, should have, or would be nice to have.
Source	Document the stakeholder who identified the requirement.
ID	Enter a unique requirement identifier.
Technical requirement	Document the technical performance that must be met by the project or be present in the product, service, or result to satisfy a need or expectation of a stakeholder.
Priority	Prioritize the requirement category. For example, Level 1, Level 2, etc., or must have, should have, or would be nice to have.
Source	Document the stakeholder who identified the requirement.

# REQUIREMENTS TRACEABILITY MATRIX

Project Title: \_\_\_\_\_

Date Prepared: \_\_\_\_\_

Requirement Information					Relationship Traceability			
ID	Requirement	Priority	Category	Source	Objective	WBS Deliverable	Metric	Validation



## 2.6 PROJECT SCOPE STATEMENT

The Project Scope Statement is the description of the project scope, major deliverables, assumptions, and constraints. It documents the entire scope, and is considered one of the key documents of the project, since it provides a common understanding of the project scope of the project among project stakeholders.

The Project Scope Statement assists in defining, developing, and constraining the project and product scope. It uses information from the project charter and Stakeholder Requirements and progressively elaborates that information so that deliverables, project exclusions, and acceptance criteria can be defined.

The Project Scope Statement enables the project team to perform detailed planning, guides the project team's work during execution, and provides a basis for evaluating whether requests for changes or additional work are contained within or outside the project's boundaries.

The Project Scope Statement is where project constraints and assumptions are documented. Many times the initial assumptions will be documented in the Project Scope Statement and then further elaborated in an Assumption Log. The Project Scope Statement should contain at least this information:

- Product scope description
- Project deliverables
- Product acceptance criteria
- Project exclusions
- Project constraints
- Project assumptions

Use the information from your project to tailor the form to best meet your needs.

The Project Scope Statement can receive information from:

- Scope Management Plan
- Project Charter
- Requirements Documentation

It provides information to:

- Work Breakdown Structure
- Network Diagram
- Activity Duration Estimates
- Project Schedule

The Project Scope Statement is an output from the process 5.3 Define Scope in the *PMBOK® Guide—Fifth Edition*.

You can use the element descriptions in Table 2.7 to assist you in developing a Project Scope Statement.

**TABLE 2.7 Elements of a Project Scope Statement**

Document Element	Description
Product scope description	Document the characteristics of the product, service or result. The information should be progressively elaborated from the project description in the project charter and the requirements in the requirements documentation.
Project deliverables	Identify any unique and verifiable product, result, or capability to perform a service that must be produced to complete a process, phase, or project. Deliverables include project management reports and documentation.
Product acceptance criteria	Document the criteria that need to be met in order for a stakeholder to accept a deliverable. Acceptance criteria can be developed for the entire project or for each component of the project.
Project exclusions	Clearly define what is considered out of scope for the project.
Project constraints	Constraints are limitations. Constraints that can impact the project include a fixed budget, hard deliverable due dates, or specific technology.
Project assumptions	Document those assumptions about deliverables, resources, estimates, and any other aspect of the project that the team holds to be true, real, or certain, but have not validated.

# PROJECT SCOPE STATEMENT

Project Title: \_\_\_\_\_ Date Prepared: \_\_\_\_\_

## Product Scope Description

## Project Deliverables

## Project Acceptance Criteria

## Project Exclusions

## Project Constraints

## Project Assumptions

## 2.7 ASSUMPTION AND CONSTRAINT LOG

The Assumption and Constraint Log can be incorporated into the Project Scope Statement or it can be a stand-alone document. Assumptions are factors in the planning process that are considered to be true, real, or certain, without proof or demonstration. This log is a dynamic document since assumptions are progressively elaborated throughout the project. Eventually they are validated and are no longer assumptions. Constraints are limiting factors that affect the execution of the project or process. Typical constraints include a predetermined budget or fixed milestones for deliverables. Information in the Assumption and Constraint Log includes:

- Identifier
- Category
- Assumption or constraint
- Responsible party
- Due date
- Actions
- Status
- Comments

Assumptions can come from any document in the project. They can also be determined by the project team. Constraints are generally documented in the project charter and are determined by the customer, sponsor, or regulatory agencies.

Although the Assumption and Constraint Log does not explicitly provide information to any specific document, by incorporation in the Project Scope Statement, it provides useful information to:

- Work Breakdown Structure
- Network Diagram
- Activity Duration Estimates
- Project Schedule
- Risk Register

It should also be considered when developing Activity Cost Estimates and Activity Resource Requirements. You can use the element descriptions in Table 2.8 to assist you in developing an Assumption Log.

**TABLE 2.8 Elements of an Assumption Log**

Document Element	Description
ID	Identifier.
Category	The category of the assumption.
Assumption/ constraint	Those things that are considered true, real, or certain, but without proof or demonstration; or, a limitation or restriction that affects the execution of the project or process.
Responsible party	The person who is tasked with following up on the assumption to validate it as true or not.
Due date	The date by which the assumption needs to be validated.
Actions	Actions that need to be taken in order to validate assumptions.
Status	The current status of the assumption, such as active, pending, or closed.
Comments	Any additional information regarding the assumption or constraint.



# ASSUMPTION AND CONSTRAINT LOG

Project Title: \_\_\_\_\_ Date Prepared: \_\_\_\_\_

ID	Category	Assumption/Constraint	Responsible Party	Due Date	Actions	Status	Comments

## 2.8 WORK BREAKDOWN STRUCTURE

The Work Breakdown Structure (WBS) is used to decompose all the work of the project. It begins at the project level and is successively broken down into finer levels of detail. The lowest level is a work package. A work package represents a discrete deliverable that can be decomposed into activities to produce the deliverable. The needs of the project will determine the way that the WBS is organized. The second level determines the organization of the WBS. Some options for organizing and arranging the WBS include:

- Geography
- Major deliverables
- Life cycle phases
- Subprojects

The WBS should have a method of identifying the hierarchy, such as a numeric structure. The WBS can be shown as a hierarchical chart or as an outline. The approved WBS, its corresponding WBS Dictionary, and the Project Scope Statement comprise the scope baseline for the project.

Use the information from your project to tailor the WBS to best meet your needs.

The WBS can receive information from:

- Scope Management Plan
- Project Scope Statement
- Requirements Documentation

It is related to:

- WBS Dictionary
- Scope Baseline

It provides information to:

- Activity List
- Activity Cost Estimates
- Project Budget
- Risk Register
- Accepted Deliverables

The Work Breakdown Structure is an output from the process 5.4 Create WBS in the *PMBOK® Guide—Fifth Edition*.

You can use the element descriptions in Table 2.9 to assist you in developing a Work Breakdown Structure.

**TABLE 2.9 Elements of a Work Breakdown Structure**

Document Element	Description
Control account	The point where scope, schedule, and cost are integrated and used to measure project performance.
Work package	The lowest-level deliverable defined in the WBS for estimating and measuring cost and duration. Each work package rolls up to one and only one control account for reporting purposes.

# WORK BREAKDOWN STRUCTURE

Project Title: \_\_\_\_\_

Date Prepared: \_\_\_\_\_

## 1. Project

### 1.1. Major Deliverable

#### 1.1.1. Control Account

1.1.1.1. Work package

1.1.1.2. Work package

1.1.1.3. Work package

#### 1.1.2. Work package

### 1.2. Control Account

1.2.1. Work package

1.2.2. Work package

### 1.3. Major Deliverable

#### 1.3.1. Control account

#### 1.3.2. Control account

1.3.2.1. Work package

1.3.2.2. Work package

## 2.9 WBS DICTIONARY

The WBS Dictionary supports the Work Breakdown Structure by providing detail about the control accounts and work packages it contains. The Dictionary can provide detailed information about each work package or summary information at the control account level and work packages. The approved WBS, its corresponding WBS Dictionary, and the Project Scope Statement comprise the scope baseline for the project. Information in the WBS Dictionary can include:

- Code of account identifier
- Description of work
- Assumptions and constraints
- Responsible organization or person
- List of milestones
- List of schedule activities
- Resources required
- Cost estimates
- Quality requirements
- Acceptance criteria
- Technical information or references
- Agreement (contract) information

The WBS Dictionary is progressively elaborated as the planning processes progress. Once the WBS is developed, the statement of work for a particular work package may be defined, but the necessary activities, cost estimates, and resource requirements may not be known. Thus, the inputs for the WBS Dictionary are more detailed than for the WBS, and there are not as many outputs.

Use the information from your project to tailor the form to best meet your needs.

The WBS Dictionary can receive information from:

- Scope Management Plan
- Requirements Documentation
- Project Scope Statement
- Assumption Log
- Activity List
- Milestone List
- Activity Resource Requirements
- Activity Cost Estimates
- Quality Metrics
- Contracts

It is related to:

- Work Breakdown Structure
- Scope Baseline

As part of the scope baseline it provides information to:

- Risk Register
- Procurement Management Plan
- Activity List
- Activity Cost Estimates
- Project Budget
- Accepted Deliverables

The WBS Dictionary is part of the scope baselines and is an output from the process 5.4 Create WBS in the *PMBOK® Guide—Fifth Edition*.

You can use the element descriptions in Table 2.10 to assist you in developing a WBS Dictionary.

**TABLE 2.10 Elements of a WBS Dictionary**

Document Element	Description
Work package name	Enter a brief description of the work package deliverable from the WBS.
Code of account	Enter the code of account from the WBS.
Milestones	List any milestones associated with the work package.
Due dates	List the due dates for milestones associated with the work package.
ID	Enter a unique activity identifier, usually an extension of the WBS code of accounts.
Activity	Describe the activity from the activity list or the schedule.
Resource	Identify the resources, usually from the resource requirements.
Labor hours	Enter the total effort required.
Labor rate	Enter the labor rate, usually from cost estimates.
Labor total	Multiply the effort hours times the labor rate.
Material units	Enter the amount of material required.
Material cost	Enter the material cost, usually from cost estimates.
Material total	Multiply the material units times the material cost.
Total work package cost	Sum the labor, materials, and any other costs associated with the work package.
Quality requirements	Document any quality requirements or metrics associated with the work package.
Acceptance criteria	Describe the acceptance criteria for the deliverable.
Technical information	Describe or reference any technical requirements or documentation needed to complete the work package.
Agreement information	Reference any contracts or other agreements that impact the work package.

# WBS DICTIONARY

Project Title: \_\_\_\_\_ Date Prepared: \_\_\_\_\_

<b>Work Package Name:</b>			<b>Code of Account:</b>						
<b>Description of Work:</b>			<b>Assumptions and Constraints:</b>						
<b>Milestones:</b> 1. 2. 3.			<b>Due Dates:</b>						
ID	Activity	Resource	Labor			Material			Total Cost
			Hours	Rate	Total	Units	Cost	Total	
<b>Quality Requirements:</b>									
<b>Acceptance Criteria:</b>									
<b>Technical Information:</b>									
<b>Agreement Information:</b>									

## 2.10 SCHEDULE MANAGEMENT PLAN

The Schedule Management Plan is part of the project management plan. It specifies how the project schedule will be developed, monitored, and controlled. Planning how to manage the schedule can include at least:

- Scheduling methodology
- Scheduling tool
- Level of accuracy for duration estimates
- Units of measure
- Variance thresholds
- Schedule reporting information and format
- Process for identifying all the activities
- Process and guidelines for sequencing activities
- Process for estimating resources needs
- Process for estimating effort and duration
- Process for updating, managing, and controlling the schedule

In addition, the Schedule Management Plan may include information on the level of detail and timing for WBS decomposition based on rolling wave planning.

The Schedule Management Plan can receive information from:

- Project Charter
- Project Management Plan

It provides information to:

- Activity List
- Activity Attributes
- Network Diagram
- Activity Resource Requirements
- Resource Breakdown Structure
- Activity Duration Estimates
- Project Schedule
- Schedule Baseline

The Schedule Management Plan is an output from the process 6.1 Plan Schedule Management in the *PMBOK® Guide—Fifth Edition*.

You can use the element descriptions in Table 2.11 to assist you in developing a Schedule Management Plan.

**TABLE 2.11 Elements of the Schedule Management Plan**

Document Element	Description
Schedule methodology	Identify the scheduling methodology that will be used for the project, whether it is critical path, critical chain, or some other methodology.
Scheduling tool	Identify the scheduling tool(s) that will be used for the project. Tools can include scheduling software, reporting software, earned value software, etc.
Level of accuracy	Describe the level of accuracy needed for estimates. The level of accuracy may evolve over time as more information is known (progressive elaboration). If there are guidelines for rolling wave planning and the level of refinement that will be used for duration and effort estimates, indicate the levels of accuracy required as time progresses.
Units of measure	Indicate whether duration estimates will be in days, weeks, months, or some other unit of measure.
Variance thresholds	Indicate the measures that determine whether an activity, work package, or the project as a whole is on time, requires preventive action, or is late and requires corrective action.
Schedule reporting information and format	Document the schedule information required for status and progress reporting. If a specific reporting format will be used attach a copy or refer to the specific form or template.
Activity identification	Describe how activities will be identified, such as decomposition, brainstorming, interviews, etc.
Activity sequencing	Describe any guidelines for sequencing activities to create a network diagram. This can include guidance on the types of dependencies and how to document them.
Estimating resources	Indicate how resources will be estimated, loaded and managed in the scheduling tool. This can include how to work with resource pools, skill sets and levels and types of resources.
Estimating effort and duration	Indicate the estimating techniques that will be used to arrive at effort and/or duration estimates. Examples include analogous estimates, three-point estimates, parametric estimates, etc.
Updating, managing, and controlling	Document the process for updating the schedule, including update frequency, permissions, and version control. Indicate the guidelines for maintaining baseline integrity and for re-baselining if necessary.



# SCHEDULE MANAGEMENT PLAN

Project Title:

Date:

## Schedule Methodology

--

## Schedule Tools

--

Level of Accuracy

Units of Measure

Variance Thresholds

Level of Accuracy	Units of Measure	Variance Thresholds

## Schedule Reporting and Format

--

## Process Management

Activity identification	
Activity sequencing	
Estimating resources	
Estimating effort and duration	
Updating, monitoring, and controlling	

## 2.11 ACTIVITY LIST

The Activity List defines all the activities necessary to complete the project work. It also describes the activities in sufficient detail so that the person performing the work understands the requirements necessary to complete it correctly. The Activity List contains:

- Activity identifier
- Activity name
- Description of work

Use the information from your project to tailor the form to best meet your needs.

The Activity List can receive information from:

- Schedule Management Plan
- Scope Baseline (particularly the deliverables from the WBS)

It is related to:

- Activity Attributes
- Milestone List

It provides information to:

- Network Diagram
- Activity Resource Requirements
- Activity Duration Estimates
- Gantt Chart or other schedule presentation

The Activity List is an output from process 6.2 Define Activities in the *PMBOK® Guide—Fifth Edition*. You can use the element descriptions in Table 2.12 to assist you in developing an Activity List.

**TABLE 2.12 Elements of an Activity List**

Document Element	Description
ID	Unique identifier.
Activity name	Document a brief statement that summarizes the activity. The activity name starts with a verb and is usually only a few words that describe a unique result of the activity, such as “Design deliverable A” or “Test unit B.”
Description of work	If needed use this section to provide more detail to the activity description. For example if a specific process or method of doing the work is needed.

# ACTIVITY LIST

Project Title: \_\_\_\_\_ Date Prepared: \_\_\_\_\_

ID	Activity	Description of Work

## 2.12 ACTIVITY ATTRIBUTES

Activity attributes are the details about the activity. Sometimes the information is entered directly into the schedule software. Other times the information is collected in a form that can be used later to assist in building the schedule model. Activity attributes can include:

- Activity identifier or code
- Activity name
- Activity description
- Predecessor and successor activities
- Logical relationships
- Leads and lags
- Imposed dates
- Constraints
- Assumptions
- Resource requirements and skill levels
- Geography or location of performance
- Type of effort

The activity attributes are progressively added and elaborated as the planning processes progress. Once the Activity List is complete, the description of work for a particular activity may be defined but the necessary attributes, such as logical relationships and resource requirements, may not be known. Thus, the inputs for the Activity Attributes are more detailed than for the Activity List and are added to as new information becomes available.

Use the information from your project to tailor the form to best meet your needs.

The Activity Attributes can receive information from:

- Schedule Management Plan
- Activity List
- Network Diagram
- Scope Baseline
- Assumption and Constraint Log
- Activity Resource Requirements

It is related to:

- Activity List
- Milestone List

It provides information to:

- Network Diagram
- Resource Requirements
- Duration Estimates
- Project Schedule

Activity Attributes are an output from process 6.2 Define Activities in the *PMBOK® Guide—Fifth Edition*. You can use the element descriptions in Table 2.13 to assist you in developing the Activity Attributes.

**TABLE 2.13 Elements of Activity Attributes**

<b>Document Element</b>	<b>Description</b>
ID	Unique identifier
Activity Name	Document a brief statement that summarizes the activity. The activity name starts with a verb and is usually only a few words that describe a unique result of the activity, such as “Design deliverable A” or “Test unit B.”
Description of work	A description of the activity in enough detail that the person(s) performing the work understand what is required to complete it.
Predecessor and successor activities	Identify any predecessor activities that must occur before the activity. Identify any successor activities that can’t occur until after the activity.
Logical relationships	Describe the nature of the relationship between predecessor or successor activities, such as start-to-start, finish-to-start, or finish-to-finish.
Leads and lags	Any required delays between activities (lag) or accelerations (lead) that apply to the logical relationships.
Imposed dates	Note any required dates for start, completion, reviews, or accomplishments.
Constraints	Document any limitations associated with the activity such as finish-no-later-than dates, approaches to work, resources, etc.
Assumptions	Document any assumptions associated with the activity such as availability of resources, skill sets, or other assumptions that impact the activity.
Required resources and skill levels	Document the number and roles of people needed to complete the work.
Geography or location of performance	If the work is to be completed somewhere other than at the performing organization’s site, indicate the location.
Type of effort	Indicate if the work is a fixed duration, fixed amount of effort, level of effort, apportioned effort, or other type of work.

# ACTIVITY ATTRIBUTES

Project Title: \_\_\_\_\_ Date Prepared: \_\_\_\_\_

<b>ID:</b>	<b>Activity:</b>				
<b>Description of Work:</b>					
<b>Predecessors</b>	<b>Relationship</b>	<b>Lead or Lag</b>	<b>Successor</b>	<b>Relationship</b>	<b>Lead or Lag</b>
<b>Number and Type of Resources Required:</b>		<b>Skill Requirements:</b>		<b>Other Required Resources:</b>	
<b>Type of Effort:</b>					
<b>Location of Performance:</b>					
<b>Imposed Dates or Other Constraints:</b>					
<b>Assumptions:</b>					

## 2.13 MILESTONE LIST

The Milestone List defines all the project milestones and describes the nature of each one. It may categorize the milestone as optional or mandatory, internal or external, interim or final, or in any other way that supports the needs of the project.

The Milestone List can receive information from:

- Schedule Management Plan
- Scope Baseline
- Project Scope Statement

It is related to:

- Activity List
- Activity Attributes

It provides information to:

- Network Diagram
- Gantt chart or other schedule presentation
- Change Requests

The Milestone List is an output from process 6.2 Define Activities in the *PMBOK® Guide—Fifth Edition*. You can use the element descriptions in Table 2.14 to assist you in developing a Milestone List.

**TABLE 2.14 Elements of a Milestone List**

Document Element	Description
Milestone Name	Milestone name that uniquely describes the milestone
Milestone description	Description of milestone in enough detail to understand what is needed to determine the milestone is complete.
Type	A description of the type of milestone, such as: <ul style="list-style-type: none"> <li>• Internal or external</li> <li>• Interim or final</li> <li>• Mandatory or optional</li> </ul>

# MILESTONE LIST

Project Title: \_\_\_\_\_

Date Prepared: \_\_\_\_\_

Milestone	Milestone Description	Type



## 2.14 NETWORK DIAGRAM

The Network Diagram is a visual display of the relationship between schedule elements. It can be produced at the activity level, the deliverable level, or the milestone level. The purpose is to visually depict the types of relationships between elements. The elements are shown at nodes that are connected by lines with arrows that indicate the nature of the relationship. Relationships can be of four types:

1. Finish-to-start (FS). This is the most common type of relationship. The predecessor element must be complete before the successor element can begin.
2. Start-to-start (SS). In this relationship, the predecessor element must begin before the successor element begins.
3. Finish-to-finish (FF). In this relationship, the predecessor element must be complete before the successor element can be complete.
4. Start-to-finish (SF). This is the least common type of relationship. The successor element must begin before the predecessor element can be complete.

In addition to the types of relationships, the Network Diagram may show modifications to the relationships, such as leads or lags:

- A *lag* is a directed delay between elements. In a finish-to-start relationship with a three-day lag, the successor activity would not start until three days after the predecessor was complete. This would be shown as FS+3d. Lag is not float.
- A *lead* is an acceleration between elements. In a finish-to-start relationship with a three-day lead, the successor activity would begin three days before the predecessor was complete. This would be shown as FS-3d.
- Leads and lags can be applied to any type of relationship.

Use the information from your project to determine the level of detail and the need for a Network Diagram.

The Network Diagram can receive information from:

- Schedule Management Plan
- Activity List
- Activity Attributes
- Milestone List
- Project Scope Statement

It provides information to:

- Project Schedule

The Network Diagram is an output from the process 6.3 Sequence Activities in the *PMBOK® Guide—Fifth Edition*.

# NETWORK DIAGRAM

Project Title: \_\_\_\_\_ Date Prepared: \_\_\_\_\_

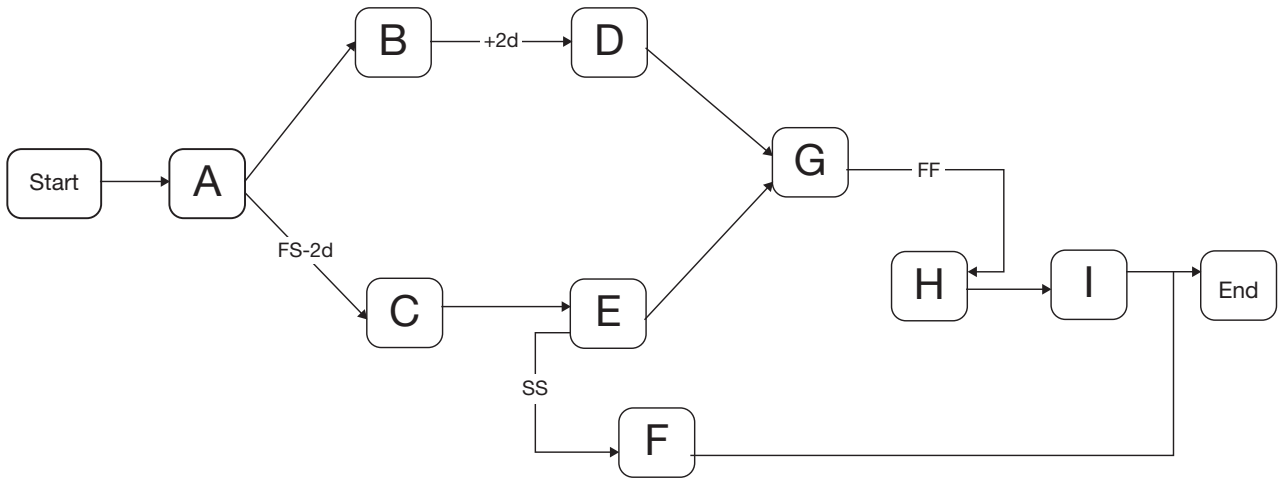

In this Network Diagram:

There is a 2-day lead between the completion of A and beginning of C.

There is a 2-day lag between the completion of B and beginning of D.

There is a start-to-start relationship between E and F.

There is a finish-to-finish relationship between G and H.

All other relationships are finish-to-start.

## 2.15 ACTIVITY RESOURCE REQUIREMENTS

The Activity Resource Requirements describe the type and quantity of resources needed to complete the project work. Resources include:

- People
- Equipment
- Material
- Supplies
- Locations (as needed)

Locations can include training rooms, testing sites, and so on.

Use the information from your project to tailor the form to meet your needs.

The Activity Resource Requirements can receive information from:

- Schedule Management Plan
- Activity List
- Activity Attributes
- Resource Calendars
- Activity Cost Estimates
- Risk Register

It provides information to:

- Resource Breakdown Structure
- Duration Estimating Worksheet
- Project Schedule
- Human Resource Management Plan
- Procurement Management Plan

The Activity Resource Requirements form is an output from process 6.4 Estimate Activity Resources in the *PMBOK® Guide—Fifth Edition*.

You can use the element descriptions in Table 2.15 to assist you in developing an Activity Resource Requirement form.

**TABLE 2.15 Elements of an Activity Resource Requirement Form**

Document Element	Description
ID	Unique identifier
Type of resource	Indicate whether the resource is a person, equipment, supplies, material, location, or some other form of resource.
Quantity	Document the amount of the resource needed for the activity.
Assumptions	Enter assumptions associated with the resource, such as availability, certifications, and so forth.
Comment	Include information on grade, competency, or other relevant information.

# ACTIVITY RESOURCE REQUIREMENTS

Project Title: \_\_\_\_\_

Date Prepared: \_\_\_\_\_

WBS ID	Type of Resource	Quantity	Assumptions
<b>Comments</b>			

## 2.16 RESOURCE BREAKDOWN STRUCTURE

The Resource Breakdown Structure is a hierarchical structure used to organize the resources by type and category. It can be shown as a hierarchical chart or as an outline.

Use the information from your project to tailor the form to best meet your needs.

The Resource Breakdown Structure is related to:

- Activity Resource Requirements

It provides information to:

- Activity Duration Estimates
- Gantt Chart or other Schedule

The Resource Breakdown Structure is an output from process 6.4 Estimate Activity Resources in the *PMBOK® Guide—Fifth Edition*

You can use the element descriptions in Table 2.16 to assist you in developing a Resource Breakdown Structure.

# RESOURCE BREAKDOWN STRUCTURE

Project Title: \_\_\_\_\_

Date Prepared: \_\_\_\_\_

## 2. Project

### 2.1. People

#### 2.1.1. Quantity of Role 1

##### 2.1.1.1. Quantity of Level 1

##### 2.1.1.2. Quantity of Level 2

##### 2.1.1.3. Quantity of Level 3

#### 2.1.2. Quantity of Role 2

### 2.2. Equipment

#### 2.2.1. Quantity of Type 1

#### 2.2.2. Quantity of Type 2

### 2.3. Materials

#### 2.3.1. Quantity of Material 1

##### 2.3.1.1. Quantity of Grade 1

##### 2.3.1.2. Quantity of Grade 2

### 2.4. Supplies

#### 2.4.1. Quantity of Supply 1

#### 2.4.2. Quantity of Supply 2

### 2.5. Locations

#### 2.5.1. Location 1

#### 2.5.2. Location 2

## 2.17 ACTIVITY DURATION ESTIMATES

Activity Duration Estimates provide information on the amount of time it will take to complete project work. They can be determined by developing an estimate for each work package using expert judgment or group decision making techniques or by using a quantitative method, such as:

- Parametric estimates
- Analogous estimates
- Three-point estimates

Duration estimates may include contingency reserve to account for risks related to uncertainty in the duration estimates.

For those activity durations driven by human resources, as opposed to material or equipment, the Activity Duration Estimates will generally convert the estimate of effort hours into days or weeks. To convert effort hours into days, take the total number of hours and divide by 8. To convert to weeks, take the total number of hours and divide by 40.

A Duration Estimating Worksheet can assist in developing accurate estimates.

Activity Duration Estimates can receive information from:

- Schedule Management Plan
- Activity List
- Activity Attributes
- Activity Resource Requirements
- Resource Breakdown Structure
- Resource Calendars
- Project Scope Statement
- Risk Register
- Resource Breakdown Structure

It provides information to:

- Schedule Baseline
- Project Schedule
- Risk Register

Activity Duration Estimates are an output from process 6.5 Estimate Activity Duration in the *PMBOK® Guide—Fifth Edition*.

You can use the element descriptions in Table 2.17 to assist you in developing Activity Duration Estimates.

**TABLE 2.17 Elements of an Activity Duration Estimate**

Document Element	Description
WBS ID	Unique WBS identifier.
Activity description	A description of the work that needs to be done.
Effort hours	The amount of labor it will take to accomplish the work; usually shown in hours, but may also be shown in days.
Duration	The length of time it will take to accomplish the work; usually shown in days, but may be shown in weeks.

# ACTIVITY DURATION ESTIMATES

Project Title: \_\_\_\_\_

Date Prepared: \_\_\_\_\_

WBS ID	Activity Description	Effort Hours	Duration Estimate



## 2.18 DURATION ESTIMATING WORKSHEET

A Duration Estimating Worksheet can help to develop duration estimates when quantitative methods are used. Quantitative methods include:

- Parametric estimates
- Analogous estimates
- Three-point estimates

Parametric estimates are derived by determining the effort hours needed to complete the work. The effort hours are then calculated by:

- Dividing the estimated hours by resource quantity (i.e., number of people assigned to the task)
- Dividing the estimated hours by the percent of time the resource(s) are available (i.e., 100 percent of the time, 75 percent of the time, or 50 percent of the time)
- Multiplying the estimated hours by a performance factor. Experts in a field generally complete work faster than people with an average skill level or novices. Therefore, a factor to account for the productivity is developed.

Duration estimates can be made even more accurate by considering that most people are productive on project work only about 75 percent of the time.

Analogous estimates are derived by comparing current work to previous similar work. The size of the previous work and the duration is compared to the expected size of the current work compared to the previous work. Then the ratio of the size of the current work is multiplied by the previous duration to determine an estimate. Various factors, such as complexity, can be factored in to make the estimate more accurate. This type of estimate is generally used to get a high-level estimate when detailed information is not available.

A three-point estimate can be used to account for uncertainty in the duration estimate. Stakeholders provide estimates for optimistic, most likely, and pessimistic scenarios. These estimates are put into an equation to determine an expected duration. The needs of the project determine the appropriate equation, but a common equation is the Beta Distribution:

$$\text{Estimated duration} = \frac{\text{Optimistic duration} + 4 \text{ Most Likely Duration} + \text{Pessimistic Duration}}{6}$$

In formulas, duration is often represented by “t” for “time.”

The Duration Estimating Worksheet can receive information from:

- Project Scope Statement
- Activity List
- Activity Attributes
- Activity Resource Requirements
- Resource Breakdown Structure
- Resource Calendars
- Risk Register

It provides information to:

- Activity Duration Estimates

Activity Duration Estimates are an output from process 6.5 Estimate Activity Duration in the *PMBOK® Guide—Fifth Edition*.

You can use the element descriptions in Table 2.18 to assist you in developing an Activity Duration Estimating Worksheet.

**TABLE 2.18 Elements of an Activity Duration Estimating Worksheet**

Document Element	Description
<b>ID</b>	<b>Unique identifier.</b>
<b>Parametric Estimates</b>	
Effort hours	Enter amount of labor it will take to accomplish the work; usually shown in hours, but may also be shown in days. Example: 150 hours
Resource quantity	Document the number of resources available. Example: 2 people
Percent available	Enter amount of time the resources are available; usually shown as the percent of time available per day or per week. Example: 75% of the time
Performance factor	Estimate a performance factor if appropriate. Generally effort hours are estimated based on the amount of effort it would take the average resource to complete the work. This can be modified if you have a highly skilled resource or someone who has very little experience. The more skilled the resource, the lower the performance factor. For example, an average resource would have a 1.0 performance factor. A highly skilled resource could get the work done faster so you multiply the effort hours times a performance factor of .8. A less skilled resource will take longer to get the work done so you would multiply the effort hours times 1.2. Example: A skilled worker has a performance factor of .8
Duration estimate	Divide the effort hours by the resource quantity times the percent available times the performance factor to determine the length of time it will take to accomplish the work. The equation is: $\frac{\text{Effort}}{\text{Quantity} \times \% \text{ Available} \times \text{Performance Factor}} = \text{Duration}$ Example: $\frac{150}{(2 \times .75 \times .8)} = 125 \text{ hours}$
<b>Analogous Estimates</b>	
Previous activity	Enter a description of the previous activity. Example: Build a 160 square foot deck.
Previous duration	Document the duration of the previous activity. Example: 10 days
Current activity	Describe how the current activity is different. Example: Build a 200 square foot deck.
Multiplier	Divide the current activity by the previous activity to get a multiplier. Example: $200/160 = 1.25$
Duration estimate	Multiply the duration for the previous activity by the multiplier to calculate the duration estimate for the current activity. Example: $10 \text{ days} \times 1.25 = 12.5 \text{ days}$
<b>Three-Point Estimate (Beta Distribution)</b>	
Optimistic duration	Determine an optimistic duration estimate. Optimistic estimates assume everything will go well and there won't be any delays in material and that all resources are available and will perform as expected. Example: 20 days

Document Element	Description
Most likely duration	Determine a most likely duration estimate. Most likely estimates assume that there will be some delays but nothing out of the ordinary. Example: 25 days
Pessimistic duration	Determine a pessimistic duration estimate. Pessimistic estimates assume there are significant risks that will materialize and cause delays. Example: 36 days
Weighting equation	Weight the three estimates and divide. The most common method of weighting is the Beta Distribution: $tE = \frac{(tO + 4 tM + tP)}{6}$ Example = $\frac{(20 + 4(25) + 36)}{6}$
Expected duration	Enter the expected duration based on the Beta Distribution calculation. Example: 26 days

# DURATION ESTIMATING WORKSHEET

Project Title: \_\_\_\_\_

Date Prepared: \_\_\_\_\_

Parametric Estimates					
WBS ID	Effort Hours	Resource Quantity	% Available	Performance Factor	Duration Estimate
Analogous Estimates					
WBS ID	Previous Activity	Previous Duration	Current Activity	Multiplier	Duration Estimate
Three Point Estimates					
WBS ID	Optimistic Duration	Most Likely Duration	Pessimistic Duration	Weighting Equation	Expected Duration Estimate

## 2.19 PROJECT SCHEDULE

The Project Schedule combines the information from the Activity List, Network Diagram, Activity Resource Requirements, Activity Duration Estimates, and any other relevant information to determine the start and finish dates for project activities. A common way of showing a schedule is via Gantt chart showing the dependencies between activities. The sample Gantt chart is for designing, building, and installing kitchen cabinets. It shows the:

- WBS identifier
- Activity name
- Start dates
- Finish dates
- Resource name (next to the bar)

The information on your schedule can be much more detailed, depending on the needs of the project. Scheduling software provides many options to record and display information.

Another method of showing schedule information is to create a Milestone Chart, which shows only the dates of the important events or key deliverables. The sample Milestone Chart is for constructing a house. It shows the activity milestones as well as their dependencies. Showing dependencies on a Milestone Chart is optional.

The Project Schedule can receive information from:

- Schedule Management Plan
- Activity List
- Activity Attributes
- Network Diagram
- Activity Resource Requirements
- Resource Breakdown Structure
- Resource Calendar
- Activity Duration Estimates
- Project Scope Statement
- Risk Register

It provides information to:

- Activity Cost Estimates
- Project Budget
- Procurement Management Plan

The Project Schedule is an output from process 6.7 Develop Schedule in the *PMBOK® Guide—Fifth Edition*.

# PROJECT SCHEDULE

Project Title: \_\_\_\_\_

Date Prepared: \_\_\_\_\_

Sample Gantt Chart

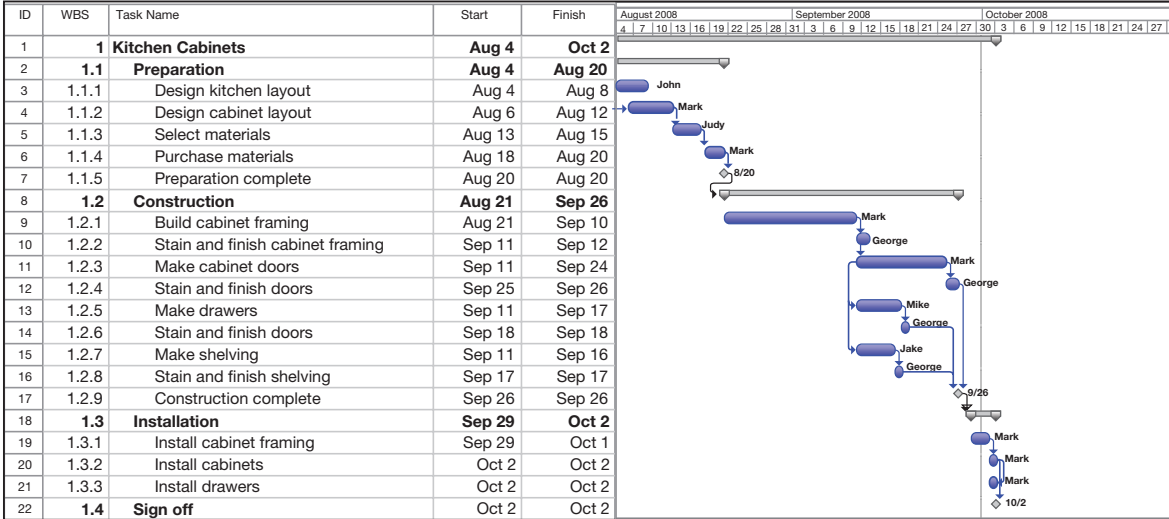

# PROJECT SCHEDULE

Sample Milestone Chart

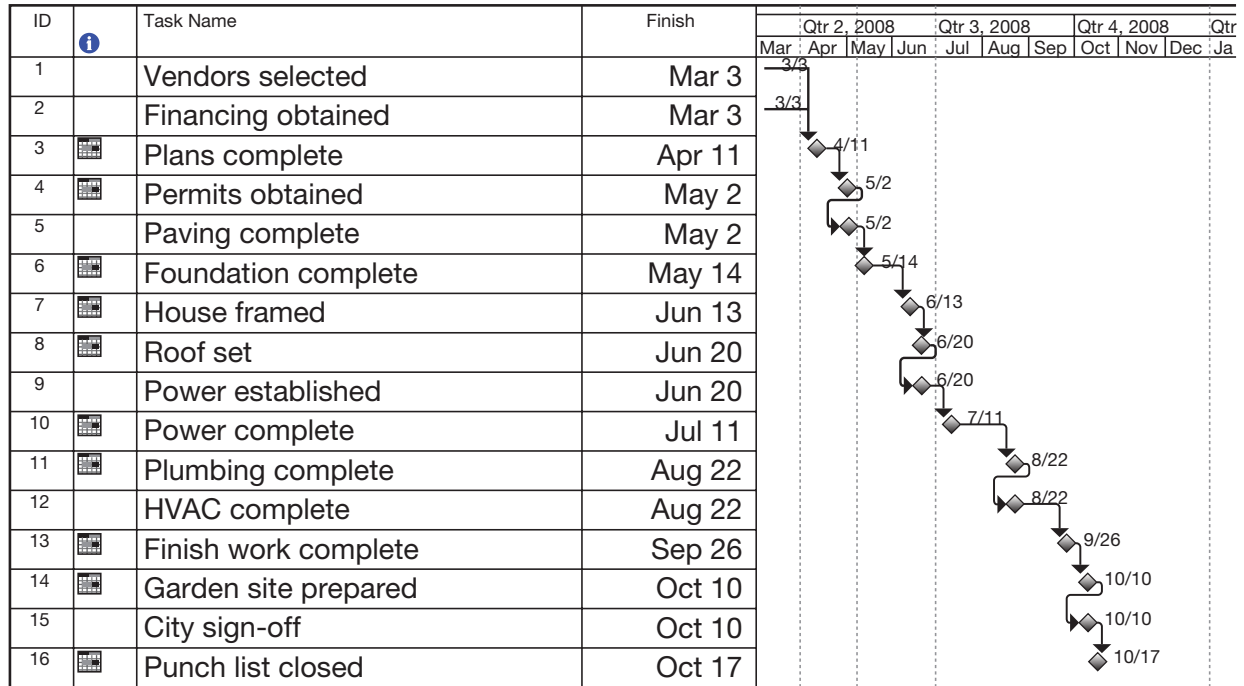

## 2.20 COST MANAGEMENT PLAN

The Cost Management Plan is a part of the project management plan. It specifies how the project costs will be estimated, structured, monitored, and controlled. The Cost Management Plan can include the following information:

- Level of accuracy for cost estimates
- Units of measure
- Variance thresholds
- Rules for performance measurement
- Cost reporting information and format
- Process for estimating costs
- Process for developing a time-phased budget
- Process for monitoring and controlling costs

In addition, the Cost Management Plan may include information on the level of authority associated with cost and budget allocation and commitment, funding limitations, and options and guidelines on how and when costs get recorded for the project.

The Cost Management Plan can receive information from the:

- Project Charter
- Project Management Plan

It provides information to:

- Activity Cost Estimates
- Cost Baseline
- Risk Register

The Cost Management Plan is an output from the process 7.1 Plan Cost Management in the *PMBOK® Guide—Fifth Edition*.

You can use the element descriptions in Table 2.19 to assist you in developing a Cost Management Plan.

**TABLE 2.19 Elements of a Cost Management Plan**

Document Element	Description
Level of accuracy	Describe the level of accuracy needed for estimates. The level of accuracy may evolve over time as more information is known (progressive elaboration). If there are guidelines for rolling wave planning and the level of refinement that will be used for cost estimates, indicate the levels of accuracy required as time progresses.
Units of measure	Indicate whether cost estimates will be in hundreds, thousands, or some other unit of measure. Also indicate the currency that will be used if you are on an international project.
Control thresholds	Indicate the measures that determine whether an activity, work package, or the project as a whole is on budget, requires preventive action, or is over budget and requires corrective action. Usually indicated as a percent deviation from the baseline.
Rules for performance measurement	Identify the level in the WBS where progress and expenditures will be measured. For projects that use earned value management, describe the measurement method that will be used, such as weighted milestones, fixed-formula, percent complete, etc. Document the equations that will be used to forecast future costs based on current performance trends.



Document Element	Description
Cost reporting information and format	Document the cost information required for status and progress reporting. If a specific reporting format will be used attach a copy or refer to the specific form or template.
Estimating costs	Indicate the estimating techniques that will be used to arrive at cost estimates. Examples include analogous estimates, three-point estimates, parametric estimates, etc.
Developing a budget	Document how the project baseline will be developed. Include information on how contingency and management reserve will be handled.
Updating, managing, and controlling	Document the process for updating the budget, including update frequency, permissions, and version control. Indicate the guidelines for maintaining baseline integrity and for re-baselining if necessary.

# COST MANAGEMENT PLAN

Project Title: \_\_\_\_\_ Date: \_\_\_\_\_

Level of Accuracy:	Units of Measure:	Control Thresholds:

## Rules for Performance Measurement:

--

## Cost Reporting and Format:

--

## Process Management:

<i>Estimating costs</i>	
<i>Developing the budget</i>	
<i>Updating, monitoring and controlling</i>	

## 2.21 ACTIVITY COST ESTIMATES

Activity Cost Estimates provide information on the cost of resources necessary to complete project work, including labor, equipment, supplies, services, facilities, and material. Estimates can be determined by developing an approximation for each work package using expert judgment or by using a quantitative method such as:

- Parametric estimates
- Analogous estimates
- Three-point estimates

In addition, information on contingency reserves, the cost of quality, cost of financing, vendor bids, and indirect costs should be taken into account when developing Activity Cost Estimates.

A Cost Estimating Worksheet can assist in developing accurate estimates.

The cost estimates should provide information on how the estimate was developed, basis of estimates, assumptions and constraints, range of estimates, and confidence level.

Activity Cost Estimates can receive information from:

- Cost Management Plan
- Scope Baseline
- Project Schedule
- Human Resource Management Plan
- Risk Register

Activity Cost Estimates are related to:

- Cost Estimating Worksheet

They provide information to:

- Cost Baseline
- Activity Resource Requirements
- Risk Register
- Make-or-Buy Decisions

Activity Cost Estimates are an output from the process 7.2 Estimate Costs in the *PMBOK® Guide—Fifth Edition*.

You can use the element descriptions in Table 2.20 to assist you in developing Activity Cost Estimates.

**TABLE 2.20 Elements of an Activity Cost Estimate**

Document Element	Description
ID	Unique identifier.
Resource	The resource (person, equipment, supplies) needed for the WBS element.
Direct costs	The costs directly associated with the resource.
Indirect costs	Any indirect costs, such as overhead.
Reserve	Document contingency reserve amounts, if any.
Estimate	The approximated total cost.
Method	The method used to estimate the cost, such as analogous, parametric, etc.
Assumptions/ constraints	Document any assumptions used to estimate the cost, such as the length of time the resource will be needed.
Basis of estimates	Record the basis used to calculate the estimates, such as the hourly rate.
Range	Provide a range of estimates if applicable.
Confidence level	Document the degree of confidence in the estimate.

# ACTIVITY COST ESTIMATES

Project Title: \_\_\_\_\_ Date Prepared: \_\_\_\_\_

WBS ID	Resource	Direct Costs	Indirect Costs	Reserve	Estimate	Method	Assumptions/ Constraints	Additional Information	Range	Confidence Level

## 2.22 COST ESTIMATING WORKSHEET

A Cost Estimating Worksheet can help to develop cost estimates when quantitative methods or a bottom-up estimate are developed. Quantitative methods include:

- Parametric estimates
- Analogous estimates
- Three-point estimates
- Bottom-up estimates

Parametric estimates are derived by determining the cost variable that will be used and the cost per unit. Then the number of units is multiplied by the cost per unit to derive a cost estimate.

Analogous estimates are derived by comparing current work to previous similar work. The size of the previous work and the cost is compared to the expected size of the current work. Then the ratio of the size of the current work compared to the previous work is multiplied by the previous cost to determine an estimate. Various factors, such as complexity and price increases, can be factored in to make the estimate more accurate. This type of estimate is generally used to get a high-level estimate when detailed information is not available.

A three-point estimate can be used to account for uncertainty in the cost estimate. Stakeholders provide estimates for optimistic, most likely, and pessimistic scenarios. These estimates are put into an equation to determine an expected cost. The needs of the project determine the appropriate equation, though a common equation is a Beta Distribution:

$$\text{Estimated cost} = \frac{(\text{Optimistic Cost} + 4 \text{ Most Likely Cost} + \text{Pessimistic Cost})}{6}$$

Bottom-up estimates are detailed estimates done at the work package level. Detailed information on the work package, such as technical requirements, engineering drawings, labor duration and cost estimates, and other direct and indirect costs are used to determine the most accurate estimate possible.

The Cost Estimating Worksheet can receive information from:

- Cost Management Plan
- Scope Baseline
- Project Schedule
- Human Resource Management Plan
- Risk Register

It is related to:

- Activity Cost Estimates

Activity Cost Estimates are an output from process 7.2 Estimate Costs in the *PMBOK® Guide—Fifth Edition*. You can use the element descriptions in Table 2.21 to assist you in developing a Cost Estimating Worksheet and the element descriptions in Table 2.22 to assist you in developing a Bottom-Up Cost Estimating Worksheet.

**TABLE 2.21 Elements of a Cost Estimating Worksheet**

Document Element	Description
WBS ID	Unique WBS identifier.
<b>Parametric Estimates</b>	
Cost variable	Enter the cost-estimating driver, such as hours, square feet, gallons, or some other quantifiable measure. Example: Square feet
Cost per unit	Record the cost per unit. Example: \$9.50 per square foot
Number of units	Enter the number of units. Example: 36
Cost estimate	Multiply the number of units times the cost per unit to calculate the estimate. Example: $\$9.50 \times 36 = \$342$
<b>Analogous Estimates</b>	
Previous activity	Enter a description of the previous activity. Example: Build a 160 square foot deck.
Previous duration	Document the cost of the previous activity. Example: \$5000
Current activity	Describe how the current activity is different. Example: Build a 200 square foot deck.
Multiplier	Divide the current activity by the previous activity to get a multiplier. Example: $200/160 = 1.25$
Cost estimate	Multiply the cost for the previous activity by the multiplier to calculate the cost estimate for the current activity. Example: $\$5000 \times 1.25 = \$6250$
<b>Three-Point Estimate</b>	
Optimistic duration	Determine an optimistic cost estimate. Optimistic estimates assume all costs were identified and there won't be any cost increases in material, labor, or other cost drivers. Example: \$4000
Most likely duration	Determine a most likely cost estimate. Most likely estimates assume that there will be some cost fluctuations but nothing out of the ordinary. Example: \$5000
Pessimistic duration	Determine a pessimistic cost estimate. Pessimistic estimates assume there are significant risks that will materialize and cause cost overruns. Example: \$7500
Weighting equation	Weight the three estimates and divide. The most common method of weighting is the Beta Distribution, where c = cost: $cE = \frac{(cO + c4M + cP)}{6}$ Example: $\frac{(4000 + 4(5000) + 7500)}{6}$
Expected duration	Enter the expected cost based on the weighting calculation. Example: \$5250

**TABLE 2.22 Elements of a Bottom-Up Cost Estimating Worksheet**

<b>Document Element</b>	<b>Description</b>
WBS ID	Unique WBS identifier.
Labor hours	Enter the estimated effort hours.
Labor rate	Enter the hourly or daily rate.
Total labor	Multiply the labor hours times the labor rate.
Material	Enter quotes for material, either from vendors or multiply the amount of material times the cost per unit.
Supplies	Enter quotes for supplies, either from vendors or multiply the amount of supplies times the cost per unit.
Equipment	Enter quotes to rent, lease, or purchase equipment.
Travel	Enter quotes for travel.
Other direct costs	Enter any other direct costs and document the type of cost.
Indirect costs	Enter any indirect costs, such as overhead.
Reserve	Enter any contingency reserve cost for the work package.
Estimate	Sum the labor, materials, supplies, equipment, travel, other direct costs, indirect costs, and any reserve.

# COST ESTIMATING WORKSHEET

Project Title: \_\_\_\_\_ Date Prepared: \_\_\_\_\_

Parametric Estimates				
WBS ID	Cost Variable	Cost per Unit	Number of Units	Cost Estimate

Analogous Estimates					
WBS ID	Previous Activity	Previous Cost	Current Activity	Multiplier	Cost Estimate

Three Point Estimates					
WBS ID	Optimistic Cost	Most Likely Cost	Pessimistic Cost	Weighting Equation	Expected Cost Estimate





## 2.23 COST BASELINE

The Cost Baseline is a time-phased budget that is used to measure, monitor, and control cost performance for the project. It is developed by summing the costs of the project by time period and developing a cumulative cost curve that can be used to track actual performance, planned performance, and the funds spent.

A project may have multiple cost baselines; for example, the project manager may keep a separate baseline for labor or procurements. The baseline may or may not include contingency funds or indirect costs. When earned value measurements are being used, the baseline may be called the performance measurement baseline.

The needs of the project will determine the information that should be used in the Cost Baseline.

The Cost Baseline can receive information from:

- Cost Management Plan
- Activity Cost Estimates
- Scope Baseline
- Project Schedule
- Resource Calendars
- Risk Register
- Agreements (Contracts)

It provides information to:

- Project Management Plan

The Cost Baseline is an output from process 7.2 Determine Budget in the *PMBOK® Guide*—Fifth Edition.

# COST BASELINE

Project Title: \_\_\_\_\_ Date Prepared: \_\_\_\_\_

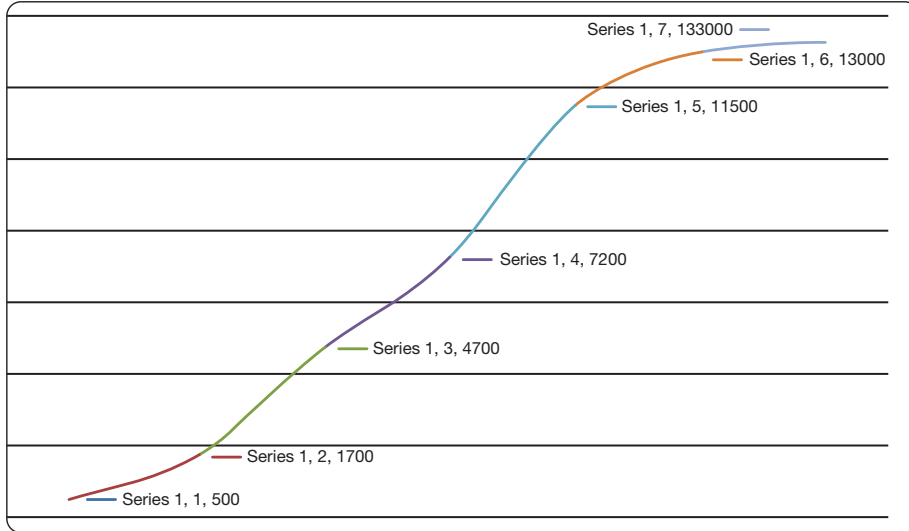

## 2.24 QUALITY MANAGEMENT PLAN

The Quality Management Plan is a component of the project management plan. It describes how quality requirements for the project will be met. Information in the Quality Management Plan can include:

- Roles and responsibilities
- Quality assurance approach
- Quality control approach
- Quality improvement approach

It may also define the tools, processes, policies, and procedures that will be used to implement the plan. Some projects may combine the Quality Management Plan with the Process Improvement Plan and the Quality Metrics or quality checklist. Other projects will have a separate document for each.

Use the information from your project to tailor the form to best meet your needs.

The Quality Management Plan can receive information from:

- Project Management Plan
- Stakeholder Register
- Requirements Documentation
- Risk Register

It is related to:

- Quality Metrics
- Process Improvement Plan

It provides information to:

- Risk Identification

The Quality Management Plan is an output from process 8.1 Plan Quality Management in the *PMBOK® Guide—Fifth Edition*.

You can use the element descriptions in Table 2.23 to assist you in developing a Quality Management Plan.

**TABLE 2.23 Elements of a Quality Management Plan**

Document Element	Description
Quality roles	Describe the role needed.
Quality responsibilities	Define the responsibilities associated with each role.
Quality planning approach	Document the approach that will be used to plan quality for the project and product. Include specific tools and techniques that will be used.
Quality assurance approach	Document the approach that will be used to manage the quality process. Include the timing and content of quality audits.
Quality control approach	Document the approach that will be used to measure the product and the project performance to ensure the product meets the quality specifications identified in the plan.
Quality improvement approach	Document the approach that will be used to continuously improve quality for the product, process, and project.

# QUALITY MANAGEMENT PLAN

Project Title: \_\_\_\_\_ Date Prepared: \_\_\_\_\_

## Quality Roles and Responsibilities

Role	Responsibilities
1.	1.
2.	2.
3.	3.
4.	4.

## Quality Planning Approach

# QUALITY MANAGEMENT PLAN

Quality Assurance Approach

Quality Control Approach

Quality Improvement Approach

## 2.25 QUALITY METRICS

Quality Metrics provide detailed specific measurements about a project, product attribute, service, or result and how it should be measured. Metrics are consulted in the quality assurance process to ensure that the processes used will meet the metric. The deliverables or processes are measured in the quality control process and compared to the metric to determine if the result is acceptable or if corrective action or rework is required. The needs of the project will determine the appropriate metrics.

Quality Metrics can receive information from:

- Project Management Plan
- Requirements Documentation
- Stakeholder Register
- Risk Register

They are related to:

- Quality Management Plan
- Process Improvement Plan

Quality Metrics are an output from process 8.1 Plan Quality Management in the *PMBOK® Guide—Fifth Edition*.

You can use the element descriptions in Table 2.24 to assist you in developing Quality Metrics.

**TABLE 2.24 Elements of Quality Metrics**

Document Element	Description
ID	WBS or other unique identifier.
Item	Describe the attribute to be measured.
Metric	Specific measurement.
Measurement Method	Method of measuring.

# QUALITY METRICS

Project Title: \_\_\_\_\_

Date Prepared: \_\_\_\_\_

ID	Item	Metric	Measurement Method



## 2.26 PROCESS IMPROVEMENT PLAN

The Process Improvement Plan is a component of the project management plan. It details the steps for analyzing project management, product development, or organizational processes to identify activities that enhance their value. The Process Improvement Plan can include:

- Description of processes for improvement
- Flowchart of the process including its inputs, outputs, and interfaces
- Process metrics (if not in the quality metric form)
- Targets for improvement
- Approach for improvement

It may also define the tools, processes, policies, and procedures that will be used to implement the plan. Use the information from your project to tailor the form to best meet your needs.

The Process Improvement Plan can receive information from:

- Project Management Plan
- Stakeholder Register
- Risk Register
- Requirements Documentation

It is related to:

- Quality Management Plan
- Quality Metrics

The Process Improvement Plan is an output from process 8.1 Plan Quality Management in the *PMBOK® Guide*—Fifth Edition.

You can use the element descriptions in Table 2.25 to assist you in developing a Process Improvement Plan.

**TABLE 2.25 Elements of a Process Improvement Plan**

<b>Document Element</b>	<b>Description</b>
Process description	<p>Describe the process including the purpose and steps involved in the process. Include any relevant information about the process that will aid in providing understanding about the process. A fictional example is the process that ABC Company uses to get a project authorized and initiated. The current process includes the following steps:</p> <ol style="list-style-type: none"> <li>1. A project initiation request is submitted to the PMO from any division in the organization.</li> <li>2. The PMO works with the requestor to develop a high-level project description and benefit statement that is sent to the finance department.</li> <li>3. The finance department compiles financial information such as the cost-benefit analysis, return on investment, payback period, and internal rate of return. The financial information is then returned to the PMO</li> <li>4. The PMO submits the high-level project description, benefits, and financial information to the Project Portfolio Steering Committee (PPSC).</li> <li>5. The PPSC meets monthly and reviews all new project requests and determines which projects will be initiated based on the current mix of projects, the financial and nonfinancial benefits, and the available resources. The PPSC decision is communicated to the PMO.</li> <li>6. If the project is approved the PMO develops a Charter and sends it back to the PPSC for review and approval. The PPSC sends the Charter back to the PMO with any revisions.</li> <li>7. The PMO assigns a project manager and the project is officially authorized and initiated.</li> </ol>
Process starting point	<p>Document the beginning point of the process. In the fictional example, the starting point is project initiation submission.</p>
Process ending point	<p>Document the end point of the process. In the fictional example, the ending point is the assignment of the project manager.</p>
Inputs	<p>List the elements required for the process to function. In the fictional example, inputs include:</p> <ul style="list-style-type: none"> <li>• The project initiation request</li> <li>• Financial information</li> <li>• Market research (if appropriate)</li> <li>• Charter templates</li> <li>• Policies and procedures associated with initiating a project from the PMO perspective and the PPSC perspective</li> </ul>
Outputs	<p>List the results from the process. In the fictional example, outputs include:</p> <ul style="list-style-type: none"> <li>• A decision to initiate a project, defer, gather more information, or decline to initiate a project</li> <li>• An approved project charter (if approved)</li> <li>• An assigned project manager (if approved)</li> </ul>
Process owner	<p>Identify the entity responsible for the maintenance and success of the process. In the fictional example, the process owner is the PMO.</p>
Process stakeholders	<p>List the stakeholders for the process. Stakeholders can be end users, maintenance and operations, or machines and equipment. In the fictional example, the stakeholders are:</p> <ul style="list-style-type: none"> <li>• Project requestor</li> <li>• PMO</li> <li>• PPSC</li> <li>• Finance department</li> <li>• The project manager</li> </ul>

*(continued)*

**TABLE 2.25 (continued)**

Document Element	Description
Metrics and control limits	<p>Document the measurements and control limits involved in the process. This can include time, number of steps or hand-offs, current errors, etc. The metrics in this section represent the current process, not the improved process. This is sometimes called the “as-is” process.</p> <p>In the fictional example, the metrics and control limits are:</p> <ul style="list-style-type: none"> <li>• Number of submissions sent back to the PMO for additional information. <i>Control limit:</i> No more than one per every 20 submitted.</li> <li>• Time to provide the financial analysis. <i>Control limit:</i> Less than 10 working days.</li> <li>• Time for the PPSC to come to a decision to authorize the project or not. <i>Control limit:</i> The lesser of 30 days or the next scheduled PPSC meeting.</li> <li>• Time for the PMO to develop a project charter. <i>Control limit:</i> 10 working days.</li> <li>• Time for PMO to assign a project manager. <i>Control limit:</i> 5 working days.</li> </ul>
Targets for improvement	<p>An explicit statement of the aspect of the process targeted for improvement and the intended metrics. This is sometimes called the “to-be” process.</p> <p>In the fictional example, the targets for improvement are:</p> <ul style="list-style-type: none"> <li>• Reduce the number of steps from 7 to 5.</li> <li>• Reduce the total average time from submission of project initiation request to project manager assigned from 65 days to an average of 40 days.</li> </ul>
Process improvement approach	<p>A description of the skills, processes, approaches, tools, and techniques that will be applied to improve the process.</p> <p>In the fictional example, the approach is:</p> <ul style="list-style-type: none"> <li>• Meet with each stakeholder and brainstorm approaches to expedite the process via combining, fast tracking, and eliminating steps. Identify if there are ways to use technology (such as intranets) to improve communication and preparation in between PPSC meetings to address any possible issues and roadblocks prior to the meetings.</li> </ul>

# PROCESS IMPROVEMENT PLAN

Project Title: \_\_\_\_\_ Date Prepared: \_\_\_\_\_

## Process Description

--

## Process Boundaries

Process Starting Point	Process Ending Point
Inputs	Outputs

# PROCESS IMPROVEMENT PLAN

## Stakeholders

Process Owner
Other Stakeholders

## Process Metrics

Metric	Control Limit
1.	1.
2.	2.
3.	3.
4.	4.
5.	5.

# PROCESS IMPROVEMENT PLAN

Targets for Improvement

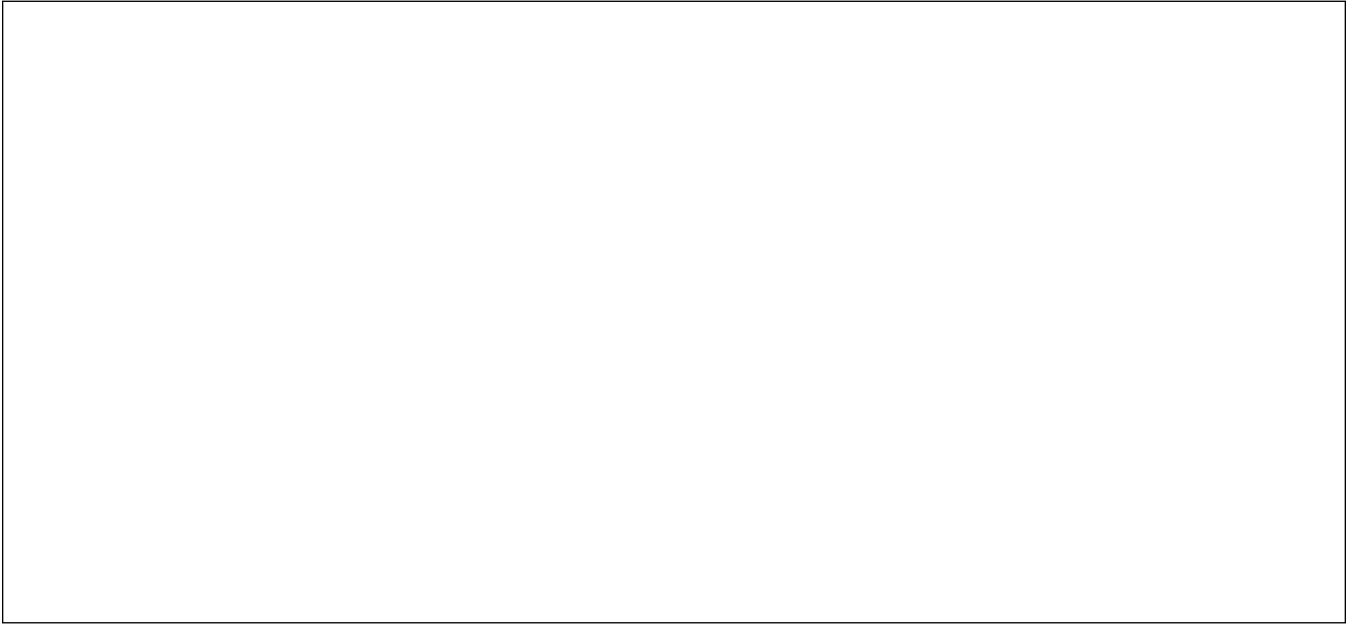

Process Improvement Approach

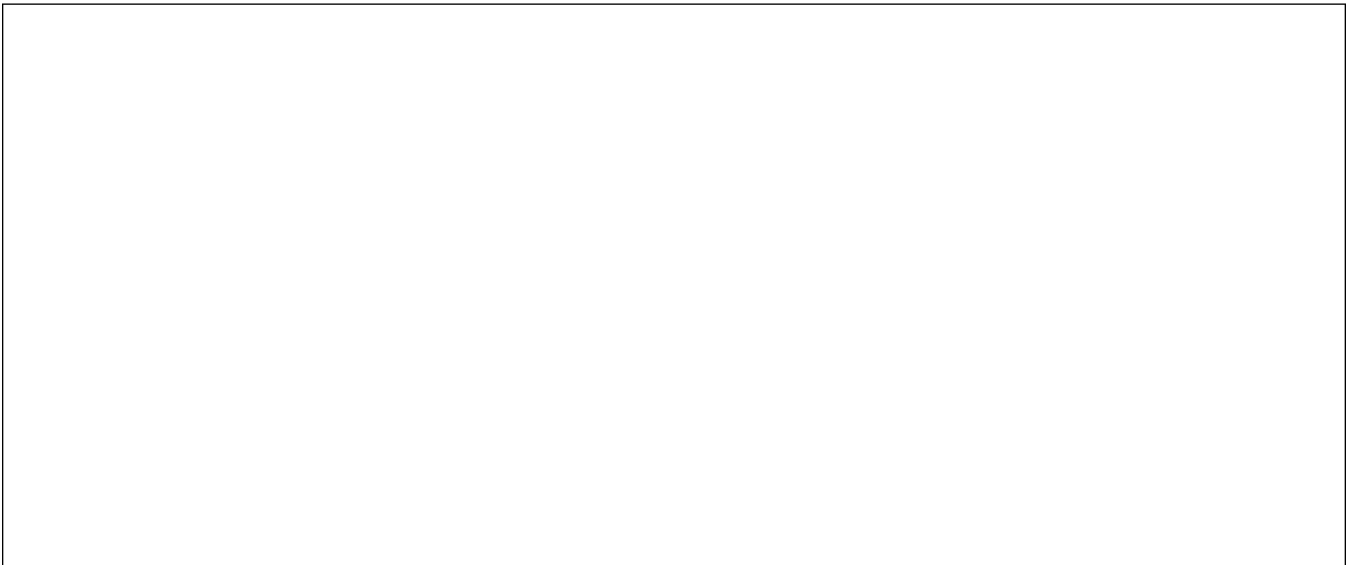

Attach a process flowchart of the current and the intended future processes.

## 2.27 RESPONSIBILITY ASSIGNMENT MATRIX

The Responsibility Assignment Matrix (RAM) shows the intersection of work packages and resources. Generally RAMs are used to show the different levels of participation on a work package by various team members, but they can also show how equipment and materials can be used on work packages. RAMs can indicate different types of participation depending on the needs of the project. Some common types include:

- Accountable
- Responsible
- Consulted
- Resource
- Informed
- Signoff

The RAM always should include a key that explains what each of the levels of participation entails. An example follows using a RACI chart, as demonstrated in the *PMBOK® Guide*. The needs of your project should determine the fields for the RAM you use.

The Responsibility Assignment Matrix can receive information from:

- Project Management Plan
- Activity Resource Requirements

It is related to:

- Resource role description

It provides information to:

- Human Resource Management Plan

The Responsibility Assignment Matrix is a tool used in process 9.1 Plan Human Resource Management in the *PMBOK® Guide—Fifth Edition*.

You can use the element descriptions in Table 2.26 to assist you in developing a Responsibility Assignment Matrix.

**TABLE 2.26 Elements of a Responsibility Assignment Matrix**

Document Element	Description
Work package	Name of the work package to which you are assigning resources. The RAM can be used at the work package level, control account level, or activity level.
Person	Identify the person, division, or organization that will be working on the project.

# RESPONSIBILITY ASSIGNMENT MATRIX

Project Title: \_\_\_\_\_ Date Prepared: \_\_\_\_\_

	Person 1	Person 2	Person 3	Person 4	Etc.
Work package 1	R	C	A		
Work package 2		A		I	R
Work package 3		R	R	A	
Work package 4	A	R	I	C	
Work package 5	C	R	R		A
Work package 6	R		A	I	
Etc.	C	A		R	R

- R = Responsible: The person performing the work.
- A = Accountable: The person who is answerable to the project manager that the work is done on time, meets requirements, and is acceptable.
- C = Consult: The person who has information necessary to complete the work.
- I = Inform: This person should be notified when the work is complete.



## 2.28 ROLES AND RESPONSIBILITIES

Roles and Responsibilities describe the attributes of a position on the project team. Some common attributes include:

- Authority
- Responsibility
- Qualifications
- Requirements

The resource Roles and Responsibilities description can receive information from:

- Activity Resource Requirements

It is related to:

- Responsibility Assignment Matrix

It provides information to:

- Human Resource Management Plan

The Roles and Responsibilities documentation is used in process 9.1 Plan Human Resource Management in the *PMBOK® Guide—Fifth Edition*.

You can use the element descriptions in Table 2.27 to assist you in developing Roles and Responsibilities.

**TABLE 2.27 Elements of Roles and Responsibilities**

Document Element	Description
Resource role description	Identify the role or job title and a brief description of the role.
Authority	Define the decision-making limits for the role. Examples include alternative selection, conflict management, prioritizing, rewarding and penalizing, etc. Indicate the reporting structure.
Responsibility	Define the activities that the role carries out and the nature of the contribution to the final product, service, or result. Examples include job duties, processes involved, and the hand-offs to other roles.
Qualifications	Describe any prerequisites, experience, licenses, seniority levels, or other qualifications necessary to fulfill the role.
Competencies	Describe specific role or job skills and competencies. May include details on languages, technology, or other information necessary to complete the roles successfully.

# ROLES AND RESPONSIBILITIES

Project Title: \_\_\_\_\_

Date Prepared: \_\_\_\_\_

## Resource Role Description

## Authority

## Responsibility

# ROLES AND RESPONSIBILITIES

## Qualifications

--

## Requirements

--

## 2.29 HUMAN RESOURCE MANAGEMENT PLAN

The Human Resource Management Plan is part of the project management plan. It describes how all aspects of human resources should be addressed. It is composed of at least three sections:

1. Roles and Responsibilities
2. Project Organization Charts
3. Staffing Management Plan

The Roles and Responsibilities section uses the information from the Roles and Responsibilities form, either by reference, link, or in summary form.<sup>1</sup> Information regarding the role description, authority, responsibility, qualifications, and competencies should be documented.

The project organizational charts can be presented in a graphic hierarchical structure or an outline form.<sup>2</sup> The charts should show the structure within the project, how the project fits in the overall organization, and any dotted-line reporting with the rest of the organization.

The staffing management section includes information on how the human resource requirements will be met. It includes information on such topics as:

- Staff acquisition
- Staff release
- Resource calendars
- Training requirements
- Rewards and recognition
- Regulation, standard, and policy compliance
- Safety

The Human Resource Management Plan can receive information from:

- Project Management Plan
- Activity Resource Requirements

It provides information to:

- Activity Cost Estimates
- Team performance assessments
- Project staff assignments
- Team member performance appraisals
- Team directory
- Risk Register

The Human Resource Management Plan is an output from 9.1 Plan Human Resource Management in the *PMBOK® Guide—Fifth Edition*.

You can use the element descriptions in Table 2.28 to assist you in developing Roles and Responsibilities.

---

1. Information from the Roles and Responsibilities section is documented in the Roles and Responsibility form in this section.

2. Organizational charts are generic and are based solely on the project and organization; therefore they are not represented in this book.

**TABLE 2.28 Elements of Roles and Responsibilities**

Document Element	Description
Staff acquisition	Document how staff will be brought on to the project. Describe any differences between internal staff team members and outsourced team members with regard to on-boarding procedures.
Staff release	Document how team members will be released from the team, including knowledge transfer, check-out procedures for staff and outsourced team members.
Resource calendars	Show any unusual resource calendars such as abbreviated workweeks, vacations, and time constraints for team members that are less than full time. A Resource calendar can include a resource histogram that shows the number of staff or the hours of work required daily, weekly, or monthly.
Training needs	Describe any required training on equipment, technology, or company processes.
Rewards and recognition	Describe any reward and recognition processes and limitations.
Regulations, standards, and policy compliance	Document any regulations, standards, or policies that must be used and how compliance will be demonstrated.
Safety	Describe any safety regulations, equipment, training, or procedures.

# HUMAN RESOURCE MANAGEMENT PLAN

Project Title: \_\_\_\_\_ Date Prepared: \_\_\_\_\_

## Roles, Responsibilities, and Authority

Role	Responsibility	Authority
1.	1.	1.
2.	2.	2.
3.	3.	3.
4.	4.	4.
5.	5.	5.
6.	6.	6.

## Project Organizational Structure

# HUMAN RESOURCE MANAGEMENT PLAN

## Staffing Management Plan

Staff Acquisition

Staff Release

--	--

## Resource Calendars

--

## Training Requirements

--

## Rewards and Recognition

--

## Regulations, Standards, and Policy Compliance

--

## Safety

--

### 2.30 COMMUNICATIONS MANAGEMENT PLAN

The Communications Management Plan is a component of the project management plan. It describes the communication needs of the project including audiences, messages, methods, and other relevant information. The plan provides information to the other processes in the project communication management knowledge area. Typical information includes:

- Stakeholder
- Information
- Method or media
- Timing or frequency
- Sender
- Communication assumptions and constraints
- Glossary of terms or acronyms

In addition, the Communications Management Plan can include resources, time, and budgets associated with communication activities, methods for addressing sensitive or proprietary information, and methods for updating the Communications Management Plan.

The Communications Management Plan can receive information from:

- Project Management Plan
- Stakeholder Register

The Communications Management Plan is an input to the Manage Stakeholders Engagement process. Although there is no form associated with that process, the information contained in the Communications Management Plan provides key information needed to manage stakeholder engagement successfully.

The Communications Management Plan is an output from process 10.1 Plan Communications Management in the *PMBOK® Guide—Fifth Edition*.

You can use the element descriptions in Table 2.29 to assist you in developing the Communications Management Plan.

**TABLE 2.29 Elements of a Communications Management Plan**

Document Element	Description
Stakeholder(s)	List the people or the groups of people who should receive project information.
Information	Describe the information to be communicated: For example, status reports, project updates, meeting minutes, etc.
Method	Describe how the information will be delivered. For example, e-mail, meetings, Web meetings, etc.
Timing or frequency	List how often the information is to be provided or under what circumstances.
Sender	Insert the name of the person or the group that will provide the information.
Communication constraints or assumptions	List any assumptions or constraints. Constraints can include descriptions of proprietary, secure, or sensitive information and relevant restrictions for distribution.
Glossary of terms or acronyms	List any terms or acronyms unique to the project or that are used in a unique way.



# COMMUNICATIONS MANAGEMENT PLAN

Project Title: \_\_\_\_\_ Date Prepared: \_\_\_\_\_

Stakeholder	Information	Method	Timing or Frequency	Sender

Assumptions	Constraints

Glossary of Terms or Acronyms

--

Attach relevant communication diagrams or flowcharts.

## 2.31 RISK MANAGEMENT PLAN

The Risk Management Plan is a component of the project management plan. It describes the approach for managing uncertainty, both threats and opportunities, for the project. Typical information includes:

- Methodology
- Roles and responsibilities for risk management
- Risk categories
- Risk management funding to identify, analyze and respond to risk
- Contingency protocols
- Frequency and timing for risk management activities
- Stakeholder risk tolerance
- Methods to track and audit risk management activities
- Definitions of probability
- Definitions of impact by objective
- Probability and impact matrix template

Not all projects need this level of detail. Use the information from your project to tailor the form to best meet your needs.

The Risk Management Plan can receive information from:

- Project Charter
- Project Management Plan
- Stakeholder Register

It provides information to:

- Risk Register

The Risk Management Plan is an input to all the other risk management processes. It describes the approach to all other risk management processes and provides key information needed to conduct those processes successfully.

The Risk Management Plan is an output from process 11.1 Plan Risk Management in the *PMBOK® Guide—Fifth Edition*.

You can use the element descriptions in Table 2.30 to assist you in developing the Risk Management Plan.

**TABLE 2.30 Elements of a Risk Management Plan**

Document Element	Description
Methodology	<p>Describe the methodology or approach to risk management. Provide information on how each of the risk management processes will be carried out, including whether quantitative risk analysis will be performed and under what circumstances.</p> <p>Identify tools, such as a risk breakdown structure, and techniques, such as interviewing, Delphi technique, etc., that will be used for each process.</p> <p>Identify any necessary data sources needed to perform risk management on the project.</p>
Roles and responsibilities	<p>Document the roles and responsibilities for various risk management activities.</p>
Risk categories	<p>Identify categorization groups used to sort and organize risks. These can be used to sort risks on the Risk Register or for a risk breakdown structure, if one is used.</p>
Risk management funding	<p>Document the funding needed to perform the various risk management activities, such as utilizing expert advice or transferring risks to a third party.</p>
Contingency protocols	<p>Describe the guidelines for establishing, measuring, and allocating both budget contingency and schedule contingency.</p>
Frequency and timing	<p>Determine the frequency of conducting formal risk management activities and the timing of any specific activities.</p>
Stakeholder risk tolerances	<p>Identify the risk tolerance levels of the organization(s) and key stakeholders on the project with regard to each objective. Cover at least scope, quality, schedule, and cost objectives.</p>
Risk tracking and audit	<p>Determine how risk management activities such as quantitative risk analysis and contingency management will be documented and tracked.</p> <p>Describe how often the risk management process will be audited, which aspects will be audited, and how the discrepancies will be addressed.</p>
Definitions of probability	<p>Document how probability will be measured and defined. Include the scale used and the definition for each level in the probability scale. For example:</p> <p>Very high = there is an 80% probability or higher that the event will occur</p> <p>High = there is a 60–80% probability that the event will occur</p> <p>Medium = there is a 40–60% probability that the event will occur</p> <p>Low = there is a 20–40% probability that the event will occur</p> <p>Very low = there is a 1–20% probability that the event will occur</p>
Definitions of impact by objective	<p>Document how impact will be measured and defined for either the project as a whole or for each objective. Include the scale used and the definition for each level in the impact scale. For example:</p> <p>Cost impacts:</p> <p>Very high = budget overrun on control account of &gt;20%</p> <p>High = budget overrun on control account between 15–20%</p> <p>Medium = budget overrun on control account between 10–15%</p> <p>Low = budget overrun on control account between 5–10%</p> <p>Very low = budget overrun on control account &lt;5%</p>
Probability and impact matrix	<p>Describe the combinations of probability and impact that indicate a high risk, a medium risk, and a low risk.</p>

# RISK MANAGEMENT PLAN

Project Title: \_\_\_\_\_ Date Prepared: \_\_\_\_\_

## Methodology

## Roles and Responsibilities

## Risk Categories

# RISK MANAGEMENT PLAN

## Risk Management Funding

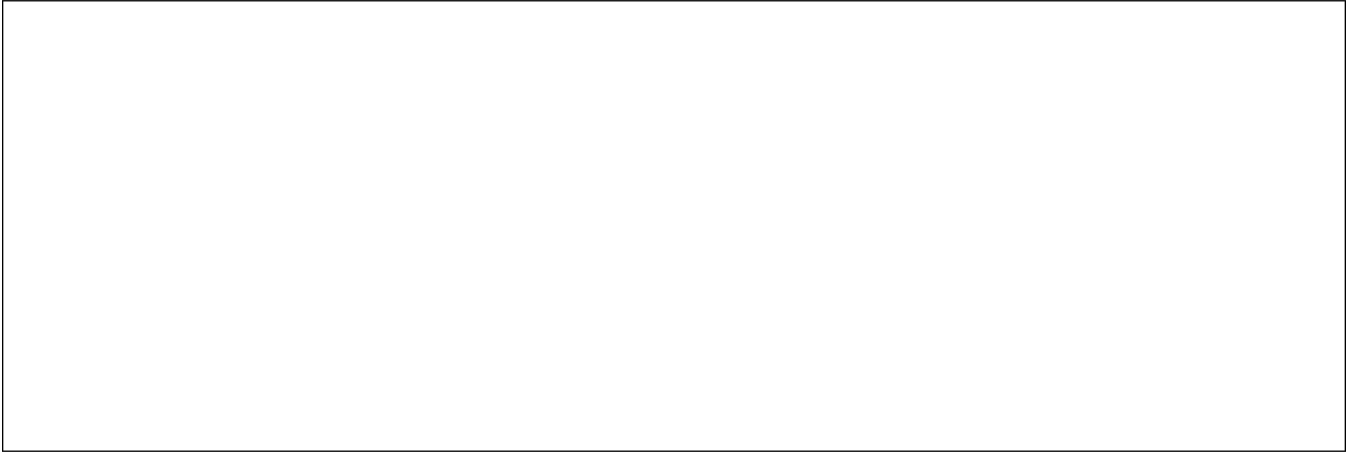

## Contingency Protocols

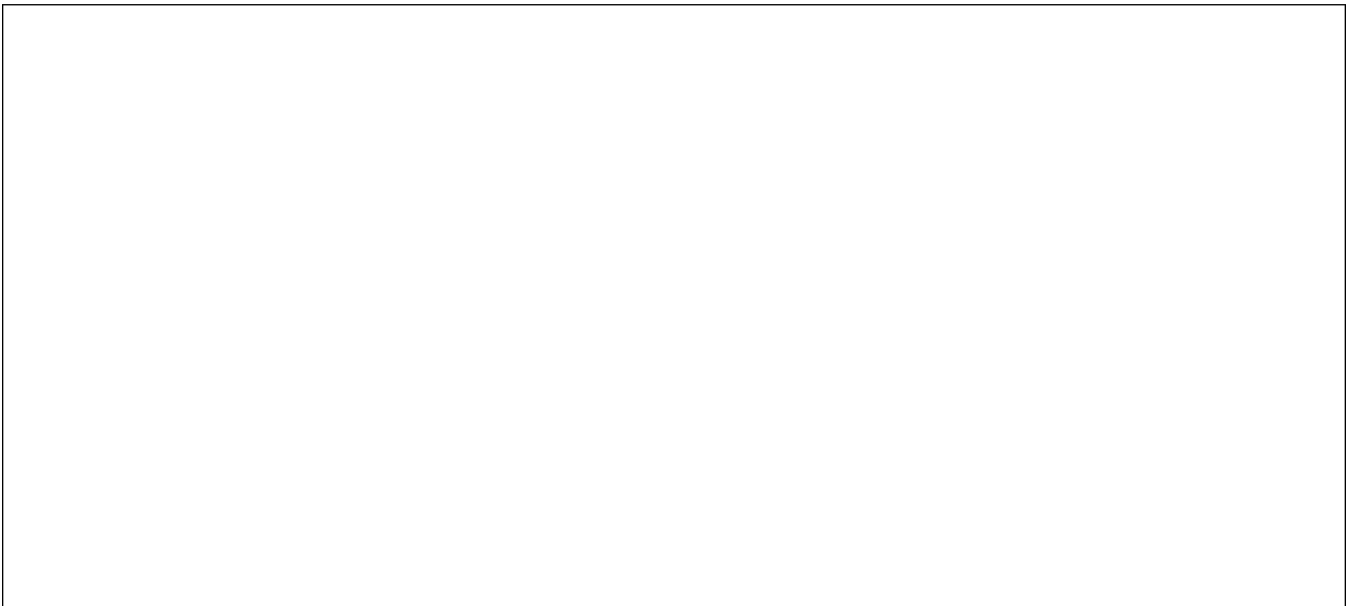

# RISK MANAGEMENT PLAN

Project Title: \_\_\_\_\_ Date Prepared: \_\_\_\_\_

## Frequency and Timing

## Stakeholder Risk Tolerances

## Tracking and Audit

# RISK MANAGEMENT PLAN

## Definitions of Probability

Very high	
High	
Medium	
Low	
Very low	

## Definitions of Impact by Objective

	Scope	Quality	Time	Cost
Very high				
High				
Medium				
Low				
Very low				

# RISK MANAGEMENT PLAN

Probability and Impact Matrix

Very high					
High					
Medium					
Low					
Very low					
	Very high	High	Medium	Low	Very low



## 2.32 RISK REGISTER

The Risk Register is a document in which the results of risk analysis and risk response planning are recorded. It is used to track information about identified risks over the course of the project. Typical information includes:

- Risk identifier
- Risk statement
- Probability of occurring
- Impact on objectives if the risk occurs
- Risk score
- Response strategies
- Revised probability
- Revised impact
- Revised score
- Responsible party
- Actions
- Status
- Comments

Not all projects need this level of detail.

Use the information from your project to tailor the Risk Register to best meet your needs. The Risk Register can receive information from anywhere in the project environment. Some documents that should be specifically reviewed for input include:

- Risk Management Plan
- Cost Management Plan
- Schedule Management Plan
- Quality Management Plan
- Human Resource Management Plan
- Scope Baseline
- Activity Cost Estimates
- Activity Duration Estimates
- Stakeholder Register
- Procurement documents

The Risk Register provides information to:

- Cost Estimates
- Quality Management Plan
- Procurement Management Plan

The Risk Register is an output from process 11.2 Identify Risks in the *PMBOK® Guide—Fifth Edition*. You can use the element descriptions in Table 2.31 to assist you in developing the Risk Register.

**TABLE 2.31 Elements of a Risk Register**

<b>Document Element</b>	<b>Description</b>
Risk ID	Enter a unique risk identifier.
Risk statement	Describe the risk event or condition. A risk statement is usually phrased as “EVENT may occur, causing IMPACT” or “If CONDITION exists, EVENT may occur, leading to EFFECT.”
Probability	Determine the likelihood of the event or condition occurring.
Impact	Describe the impact on one or more of the project objectives.
Score	If you are using numeric scoring, multiply the probability times the impact to determine the risk score. If you are using relative scoring then combine the two scores (such as high-low or medium-high).
Response	Describe the planned response strategy to the risk or condition.
Revised probability	Determine the likelihood of the event or condition occurring after the response has been implemented.
Revised impact	Describe the impact once the response has been implemented.
Revised score	Enter the revised risk score once the response has been implemented.
Responsible party	Identify the person responsible for managing the risk.
Actions	Describe any actions that need to be taken to respond to the risk.
Status	Enter the status as open or closed.
Comments	Provide any comments or additional helpful information about the risk event or condition.

# RISK REGISTER

Project Title: \_\_\_\_\_ Date Prepared: \_\_\_\_\_

Risk ID	Risk Statement	Probability	Impact		Score	Response
			Scope	Quality	Schedule	Cost

Revised Probability	Revised Impact		Revised Score	Responsible Party	Actions	Status	Comments
	Scope	Quality					

### 2.33 PROBABILITY AND IMPACT ASSESSMENT

The Probability and Impact Assessment form contains narrative descriptions of the likelihood of events occurring and the impact on the various project objectives if they do occur. It also has a key to assign an overall risk rating based on the probability and impact scores. If a Risk Management Plan is used, this information will become part of that plan. If a Risk Management Plan is not used, this form defines how risks will be analyzed.

The following document element and description table shows generic descriptions for scope, quality, schedule, and cost objectives. These descriptions are created to address both threats and opportunities. Some projects also rate stakeholder satisfaction as an objective. On smaller projects, the impacts may be grouped together without distinguishing impact by objective. Your project should determine the objectives that are used, and the descriptions for each probability and impact rating.

The sample forms use a scale of very low to very high. Some projects use a scale of 1 to 3 or 1 to 5 or percentages. As long as there is a consistent understanding of the rating and ranking system, either approach is acceptable.

Many projects prioritize project objectives. In this case, the impact scale may become more conservative for those objectives that are considered most important. In such cases the probability, impact, and risk rating may all reflect the relative importance of objectives. Another aspect of risk rating is the urgency of a risk event. Some scales rate the additional variable of urgency to indicate whether the event is imminent or in the distant future.

Use the information from your project to tailor the probability assessment, the impact assessment, and the risk rating to best meet your needs.

Information in this form provides information to:

- Probability and Impact Risk Matrix
- Risk Register

The Probability and Impact Assessment is a technique used in 11.3 Perform Qualitative Risk Analysis in the *PMBOK® Guide—Fifth Edition*.

You can use the element descriptions in Table 2.32 to assist you in developing the Probability Impact Assessment.

**TABLE 2.32 Elements of a Probability Impact Assessment**

Document Element	Description		
	Rating	Threats	Opportunities
Scope impact	Very high	The product does not meet the objectives and is effectively useless.	Scope requirements met with significant decrease in effort and/or cost
	High	The product is deficient in multiple essential requirements.	Scope requirements met with noticeable improvement in effort and/or cost
	Medium	The product is deficient in one major requirement or multiple minor requirements.	Scope requirements met with minimal improvement in effort and/or cost
	Low	The product is deficient in a few minor requirements.	Insignificant impact
	Very low	Minimal deviation from requirements.	Insignificant impact

*(continued)*

TABLE 2.32 (continued)

Document Element	Description		
	Rating	Threats	Opportunities
Quality impact	Very high	Performance is significantly below objectives and is effectively useless.	Significant improvement in outcomes / rework rate
	High	Major aspects of performance do not meet requirements.	Noticeable improvement in outcomes / rework rate
	Medium	At least one performance requirement is significantly deficient.	Some reduction in rework rate
	Low	There is minor deviation in performance.	Insignificant impact
	Very low	Minimal deviation in performance.	Insignificant impact
Schedule impact	Very high	Greater than 20% overall schedule increase.	Greater than 20% overall schedule decrease.
	High	Between 10% and 20% overall schedule increase.	Between 10% and 20% overall schedule decrease.
	Medium	Between 5% and 10% overall schedule increase.	Between 5% and 10% overall schedule decrease.
	Low	Noncritical paths have used all their float, or overall schedule increase of 1% to 5%.	Noncritical paths have used all their float, or overall schedule decrease of 1% to 5%.
	Very low	Slippage on noncritical paths but float remains.	No change on critical path duration
Cost impact	Very high	Cost increase of greater than 20%.	Cost decrease of greater than 20%.
	High	Cost increase of 10% to 20%.	Cost decrease of 10% to 20%.
	Medium	Cost increase of 5% to 10%.	Cost decrease of 5% to 10%.
	Low	Cost increase that requires use of all contingency funds.	Cost decrease of <5%.
	Very low	Cost increase that requires use of some contingency but some contingency funds remain.	Insignificant impact
Probability	Very high	The event will most likely occur: 80% or greater probability.	The event will most likely occur: 80% or greater probability.
	High	The event will probably occur: 61% to 80% probability.	The event will probably occur: 61% to 80% probability.
	Medium	The event is likely to occur: 41% to 60% probability.	The event is likely to occur: 41% to 60% probability.
	Low	The event may occur: 21% to 40% probability.	The event may occur: 21% to 40% probability.
	Very low	The event is unlikely to occur: 1% to 20% probability.	The event is unlikely to occur: 1% to 20% probability.

Document Element	Description		
	Rating	Threats	Opportunities
Risk rating	High	<p>Any event with a probability of medium or above and a very high impact on any objective.</p> <p>Any event with a probability of high or above and a high impact on any objective.</p> <p>Any event with a probability of very high and a medium impact on any objective.</p> <p>Any event that scores a medium on more than two objectives.</p>	<p>Any event with a probability of medium or above and a very high impact on any objective.</p> <p>Any event with a probability of high or above and a high impact on any objective.</p> <p>Any event with a probability of very high and a medium impact on any objective.</p> <p>Any event that scores a medium on more than two objectives.</p>
	Medium	<p>Any event with a probability of very low and a high or above impact on any objective.</p> <p>Any event with a probability of low and a medium or above impact on any objective.</p> <p>Any event with a probability of medium and a low to high impact on any objective.</p> <p>Any event with a probability of high and a very low to medium impact on any objective.</p> <p>Any event with a probability of very high and a low or very low impact on any objective.</p> <p>Any event with a probability of very low and a medium impact on more than two objectives.</p>	<p>Any event with a probability of very low and a high or above impact on any objective.</p> <p>Any event with a probability of low and a medium or above impact on any objective.</p> <p>Any event with a probability of medium and a low to high impact on any objective.</p> <p>Any event with a probability of high and a very low to medium impact on any objective.</p> <p>Any event with a probability of very high and a low or very low impact on any objective.</p> <p>Any event with a probability of very low and a medium impact on more than two objectives.</p>
	Low	<p>Any event with a probability of medium and a very low impact on any objective.</p> <p>Any event with a probability of low and a low or very low impact on any objective.</p> <p>Any event with a probability of very low and a medium or less impact on any objective.</p>	<p>Any event with a probability of medium and a very low impact on any objective.</p> <p>Any event with a probability of low and a low or very low impact on any objective.</p> <p>Any event with a probability of very low and a medium or less impact on any objective.</p>

# PROBABILITY AND IMPACT ASSESSMENT

Project Title: \_\_\_\_\_ Date Prepared: \_\_\_\_\_

## Scope Impact

Very High	
High	
Medium	
Low	
Very Low	

## Quality Impact

Very High	
High	
Medium	
Low	
Very Low	

## Schedule Impact

Very High	
High	
Medium	
Low	
Very Low	

# PROBABILITY AND IMPACT ASSESSMENT

## Cost Impact

Very High	
High	
Medium	
Low	
Very Low	

## Probability

Very High	
High	
Medium	
Low	
Very Low	

## Risk Rating

High	
Medium	
Low	



## 2.34 PROBABILITY AND IMPACT MATRIX

The Probability and Impact Matrix is a grid for mapping the probability of each risk occurrence and its impact on project objectives if that risk occurs. The Probability and Impact Assessment determines the probability and impact of the risk. It may be constructed for threats and opportunities. This matrix provides a helpful way to view the various risks on the project and prioritize them for responses. It also provides an overview of the amount of risk on the project. The project team can get an idea of the overall project risk by seeing the number of risks in each square of the matrix.

The organizations overall risk tolerance is usually indicated by the shading or range of cells within the matrix. For example an organization with a low risk threshold may rank events that fall in the very high or high range for both impact and probability as high risk. An organization with a higher risk threshold may only rank risk with a very high probability and impact as high risk.

The organization may use the relative risk rankings to specify what type risk response should be taken. For example, the organization may specify an avoidance strategy for all threats that are ranked as high risks.

A project with many risks in the dark gray zone will need more contingency to absorb the risk and likely more time and budget to develop and implement risk responses. In some situations a decision is made not to pursue a project because there is more risk than the organization is willing to absorb.

A sample Probability and Impact Matrix follows. The needs of your project will determine the exact layout of the matrix.

The Probability and Impact Matrix can receive information from:

- Probability and Impact Risk Assessment
- Risk Register

It provides information to the Risk Register.

The Probability and Impact Matrix is a tool used in 11.3 Perform Qualitative Risk Analysis in the *PMBOK*<sup>®</sup> *Guide*—Fifth Edition.

# PROBABILITY AND IMPACT MATRIX

Project Title: \_\_\_\_\_ Date Prepared: \_\_\_\_\_

Very High					
High					
Medium					
Low					
Very Low					
	Very Low	Low	Medium	High	Very High

## 2.35 RISK DATA SHEET

A Risk Data Sheet contains information about a specific identified risk. The information is filled in from the Risk Register and updated with more detailed information. Typical information includes:

- Risk identifier
- Risk description
- Status
- Risk cause
- Probability
- Impact on each objective
- Risk score
- Response strategies
- Revised probability
- Revised impact
- Revised score
- Responsible party
- Actions
- Secondary risks
- Residual risks
- Contingency plans
- Schedule or cost contingency
- Fallback plans
- Comments

Not all projects need this level of detail. Use the information from your project to tailor the form to best meet your needs.

The Risk Data Sheet can receive information from:

- Risk Register

The Risk Data Sheet can be used as an extension of the Risk Register. It can be started in process 11.2 Identify Risks in the *PMBOK® Guide*—Fifth Edition, and elaborated throughout all other risk management processes.

You can use the element descriptions in Table 2.33 to assist you in developing the Risk Data Sheet.

**TABLE 2.33 Elements of a Risk Data Sheet**

<b>Document Element</b>	<b>Description</b>
Risk ID	Enter a unique risk identifier.
Risk description	Provide a detailed description of the risk.
Status	Enter the status as open or closed.
Risk cause	Describe the circumstances or drivers that are the source of the risk.
Probability	Determine the likelihood of the event or condition occurring.
Impact	Describe the impact on one or more of the project objectives.
Score	If you are using numeric scoring, multiply the probability times the impact to determine the risk score. If you are using relative scoring, combine the two scores (high-low or medium-high).
Reponses	Describe the planned response strategy to the risk or condition.
Revised probability	Determine the likelihood of the event or condition occurring after the response has been implemented.
Revised impact	Describe the impact once the response has been implemented.
Revised score	Enter the revised risk score once the response has been implemented.
Responsible party	Identify the person responsible for managing the risk.
Actions	Describe any actions that need to be taken to respond to the risk.
Secondary risks	Describe new risks that arise out of the response strategies taken to address the risk.
Residual risk	Describe the remaining risk after response strategies.
Contingency plan	Develop a plan that will be initiated if specific events occur, such as missing an intermediate milestone. Contingency plans are used when the risk or residual risk is accepted.
Contingency funds	Determine the funds needed to protect the budget from overrun.
Contingency time	Determine the time needed to protect the schedule from overrun.
Fallback plans	Devise a plan to use if other response strategies fail.
Comments	Provide any comments or additional helpful information about the risk event or condition.

# RISK DATA SHEET

Project Title: \_\_\_\_\_ Date Prepared: \_\_\_\_\_

Risk ID	Risk Description						
Status	Risk Cause						
Probability	Impact				Score	Responses	
	Scope	Quality	Schedule	Cost			
Revised Probability	Revised Impact				Revised Score	Responsible Party	Actions
	Scope	Quality	Schedule	Cost			
Secondary Risks							
Residual Risk							
Contingency Plan					Contingency Funds		
					Contingency Time		
Fallback Plans							
Comments							

## 2.36 PROCUREMENT MANAGEMENT PLAN

The Procurement Management Plan is a component of the project management plan that describes how a project team will acquire goods and services from outside the performing organization. It describes how all aspects of a procurement will be managed. The plan provides information to the other processes in the Project Procurement Management knowledge area. Typical information includes:

- Contract type
- Procurement roles, responsibility, and authority
- Standard procurement documents
- Procurement constraints and assumptions
- Bonding and insurance requirements
- Statement of work requirements
- Prequalified sellers or buyers lists
- Selection criteria
- Contract performance metrics

Procurements must be integrated with the rest of the project work. Additional information on integration can include:

- WBS integration requirements
- Schedule integration requirements, including lead times and milestones
- Documentation requirements
- Risk management requirements
- Performance reporting requirements

The Procurement Management Plan can receive information from:

- Project Management Plan
- Requirements Documentation
- Risk Register
- Project Schedule
- Activity Resource Requirements
- Activity Cost Estimates
- Stakeholder Register

It provides information to:

- Risk Register
- Stakeholder Register
- Change Requests

The Procurement Management Plan is an input to the Conduct Procurements, Control Procurements, and Close Procurements processes. Although no forms from these processes relate back to the Procurement Management Plan, the information contained in the Procurement Management Plans provides key information needed to conduct those processes successfully.

The Procurement Management Plan is an output from process 12.1 Plan Procurement Management in the *PMBOK® Guide—Fifth Edition*.

You can use the element descriptions in Table 2.34 to assist you in developing the Procurement Management Plan.

**TABLE 2.34 Elements of a Procurement Management Plan**

Document Element	Description	
Contract type	Identify the contract type, incentive, or award fees and the criteria for such fees.	
Procurement authority	Describe the project manager’s decision authority and limitations, including at least: budget, signature level, contract changes, negotiation, and technical oversight.	
Roles and responsibilities	Project manager: Define the responsibilities of the project manager and the team. Procurement department: Describe the responsibilities of the procurement or contracting representative and department.	
Standard procurement documents	List any standard procurement forms, documents, policies, and procedures relevant to procurements.	
Bonding and insurance requirements	Define bonding or insurance requirements that must be met by bidders.	
Selection criteria	Weight/Criteria: Identify selection criteria and their relative weighting.	
Procurement assumptions and constraints	Identify and document relevant assumptions and constraints related to the procurement process.	
Integration requirements	WBS	Define how the contractor’s WBS should integrate with the project WBS.
	Schedule	Define how the contractor’s schedule should integrate with the project schedule, including milestones and long lead items.
	Documentation	Define any documentation needed from the contractor and how that documentation will integrate with project documentation.
	Risk	Define how risk identification, analysis, and tracking will integrate with the project risk management.
	Performance reporting	Define how the contractor’s performance reporting should integrate with the project status reporting, including information on scope, schedule, and cost status reporting.
Performance metrics	Document any metrics that will be used to evaluate the seller’s performance on the contract, including the domains of cost, schedule, and quality metrics.	

# PROCUREMENT MANAGEMENT PLAN

Project Title: \_\_\_\_\_ Date Prepared: \_\_\_\_\_

## Procurement Authority

--

## Roles and Responsibilities:

Project Manager	Procurement Department
1.	1.
2.	2.
3.	3.
4.	4.
5.	5.

## Standard Procurement Documents

<ol style="list-style-type: none"><li>1.</li><li>2.</li><li>3.</li><li>4.</li><li>5.</li></ol>
--

## Contract Type

--



# PROCUREMENT MANAGEMENT PLAN

## Bonding and Insurance Requirements

--

## Selection Criteria

Weight	Criteria

## Procurement Assumptions and Constraints

--

# PROCUREMENT MANAGEMENT PLAN

## Integration Requirements

WBS	
Schedule	
Documentation	
Risk	
Performance Reporting	

## Performance Metrics

Domain	Metric Measurement

## 2.37 SOURCE SELECTION CRITERIA

Source Selection Criteria is a set of attributes desired by the buyer that a seller must meet or exceed to be selected for a contract. The Source Selection Criteria form is an aid in determining and rating the criteria that will be used to evaluate bid proposals. This is a multistep process.

1. The criteria to evaluate bid responses is determined.
2. A weight is assigned to each criterion. The sum of all the criteria must equal 100 percent.
3. The range of ratings for each criterion is determined, such as 1–5 or 1–10.
4. The performance necessary for each rating is defined.
5. Each proposal is evaluated against the criteria and is rated accordingly.
6. The weight is multiplied by the rate and a score for each criterion is derived.
7. The scores are totaled and the highest total score is the winner of the bid.

Evaluation criteria commonly include such items as:

- Technical expertise
- Prior experience
- Schedule
- Management control and systems
- Price
- Quality
- Intellectual property rights
- Warranty
- Life cycle cost
- Risk management approach

This is just a sample of the information that can be evaluated. Use the information on your project to tailor the criteria and rating to best meet your needs. This information is entered into a spreadsheet for tallying. Because the output is a simple spreadsheet, no example is provided.

The Source Selection Criteria is an output from process 12.1 Plan Procurement Management in the *PMBOK® Guide—Fifth Edition*.

You can use the element descriptions in Table 2.35 to assist you in developing Source Selection Criteria.

**TABLE 2.35 Elements of Source Selection Criteria**

Document Element	Description
Criteria	1 Describe what a 1 means for the criteria. For example, for experience, it may mean that the bidder has no prior experience.
	2 Describe what a 2 means for the criteria. For example, for experience, it may mean that the bidder has done one similar job.
	3 Describe what a 3 means for the criteria. For example, for experience, it may mean that the bidder has done three to five similar jobs.
	4 Describe what a 4 means for the criteria. For example, for experience, it may mean that the bidder has done five to ten similar jobs.
	5 Describe what a 5 means for the criteria. For example, for experience, it may mean that the job is the bidder’s core competency.
Weight	Enter the weight for each criterion. Total weight for all criteria must equal 100%.
Candidate rating	Enter the rating per the criteria above.
Candidate score	Multiply the weight times the rating.
Total	Sum the scores for each candidate.

# SOURCE SELECTION CRITERIA

Project Title: \_\_\_\_\_ Date Prepared: \_\_\_\_\_

	1	2	3	4	5
Criteria 1					
Criteria 2					
Criteria 3					
Criteria 4					
Criteria 5					

	Weight	Candidate 1 Rating	Candidate 1 Score	Candidate 2 Rating	Candidate 2 Score	Candidate 3 Rating	Candidate 3 Score
Criteria 1							
Criteria 2							
Criteria 3							
Criteria 4							
Criteria 5							
Totals							

### 2.38 STAKEHOLDER MANAGEMENT PLAN

The Stakeholder Management Plan is a component of the project management plan. It describes the strategies that will be used to effectively manage stakeholder participation on the project. The plan provides information to the other processes in the project stakeholder management knowledge area. Typical information includes:

- Stakeholder engagement information
- Stakeholder communication requirements
- Information on the relationships among stakeholders
- Approaches to effectively manage stakeholder engagement

In addition, the Stakeholder Management Plan can include methods for updating and refining the plan throughout the project.

The Stakeholder Management Plan can receive information from:

- Project Management Plan
- Stakeholder Register

It provides information to:

- Requirements Documentation

The Stakeholder Management Plan is an output from process 13.2 Plan Stakeholder Management in the *PMBOK® Guide—Fifth Edition*.

You can use the element descriptions in Table 2.37 to assist you in developing the Plan Stakeholder Management Plan.

**TABLE 2.37 Elements of a Plan Stakeholder Management Plan**

Document Element	Description
Stakeholder Engagement Assessment Matrix	Use information from the Stakeholder Register to document stakeholders. Document “current” stakeholder engagement level with a “C” and “desired” stakeholder engagement with a “D.” A common format includes the following stakeholder participation descriptions: <b>Unaware.</b> Unaware of the project and its potential impacts <b>Resistant.</b> Aware of the project and potential impacts and resistant to the change <b>Neutral.</b> Aware of the project yet neither supportive nor resistant <b>Supportive.</b> Aware of the project and potential impacts and supportive of change <b>Leading.</b> Aware of the project and potential impacts and actively engaged in ensuring project is successful
Communication needs	Describe the information to be communicated to each stakeholder, including the content, level of detail, method of distribution, and reason for distribution, if it is not obvious.
Method or medium	Identify the method or media that will be used to communicate the information.
Timing or frequency	List how often the information is to be provided or under what circumstances.
Stakeholder changes	Describe any pending additions, deletions, or changes to stakeholders and the potential impact to the project.
Inter-relationships	List any relationships between and among stakeholder groups.
Stakeholder engagement approach	Describe the approach you will use with each stakeholder to move them to the preferred level of engagement.

# STAKEHOLDER MANAGEMENT PLAN

Project Title: \_\_\_\_\_ Date Prepared: \_\_\_\_\_

Stakeholder	Unaware	Resistant	Neutral	Supportive	Leading

C = Current level of engagement    D = Desired level of engagement

Stakeholder	Communication Needs	Method/Medium	Timing/Frequency

Pending Stakeholder Changes

# STAKEHOLDER MANAGEMENT PLAN

## Stakeholder Relationships

--

## Stakeholder Engagement Approach

Stakeholder	Approach

### 2.39 CHANGE MANAGEMENT PLAN

The Change Management Plan is a component of the project management plan. It describes how change will be managed on the project. Typical information includes:

- Structure and membership of a change control board
- Definitions of change
- Change control board
  - Roles
  - Responsibilities
  - Authority
- Change management process
  - Change request submittal
  - Change request tracking
  - Change request review
  - Change request disposition

The Change Management Plan is related to:

- Change Log
- Change Request form

It provides information to:

- Project Management Plan

You can use the element descriptions in Table 2.38 to assist you in developing the Change Management Plan.

**TABLE 2.38 Elements of a Change Management Plan**

Document Element	Description								
Change Management Approach	Describe the degree of change control and how change control will integrate with other aspects of project management								
Definitions of Change	Schedule change: Define a schedule change versus a schedule revision. Indicate when a schedule variance needs to go through the change control process to be rebaselined. Budget change: Define a budget change versus a budget update. Indicate when a budget variance needs to go through the change control process to be rebaselined. Scope change: Define a scope change versus a change in approach. Indicate when a scope variance needs to go through the change control process to be rebaselined. Project document changes: Define when updates to project management documents or other project documents need to go through the change control process to be rebaselined.								
Change Control Board	<table style="width: 100%; border-collapse: collapse;"> <tr> <td style="width: 30%;">Name</td> <td>Individual’s name</td> </tr> <tr> <td>Role</td> <td>Position on the change control board</td> </tr> <tr> <td>Responsibility</td> <td>Responsibilities and activities required of the role</td> </tr> <tr> <td>Authority</td> <td>Authority level for approving or rejecting changes</td> </tr> </table>	Name	Individual’s name	Role	Position on the change control board	Responsibility	Responsibilities and activities required of the role	Authority	Authority level for approving or rejecting changes
Name	Individual’s name								
Role	Position on the change control board								
Responsibility	Responsibilities and activities required of the role								
Authority	Authority level for approving or rejecting changes								



Document Element	Description	
Change Control Process	Change request submittal	Describe the process used to submit change requests, including who receives requests and any special forms, policies or procedures that need to be used.
	Change request tracking	Describe the process for tracking change requests from submittal to final disposition.
	Change request review	Describe the process used to review change requests, including analysis of impact on project objectives such as schedule, scope, cost, etc.
	Change request disposition	Describe the possible outcomes such as accept, defer, or reject.

# CHANGE MANAGEMENT PLAN

Project Title: \_\_\_\_\_ Date Prepared: \_\_\_\_\_

## Change Management Approach:

--

## Definitions of Change:

Schedule change:
Budget change:
Scope change:
Project document changes:

## Change Control Board:

Name	Role	Responsibility	Authority

## Change Control Process:

Change request submittal	
Change request tracking	
Change request review	
Change request disposition	

Attach relevant forms used in the change control process.

# Executing Forms

## 3.0 EXECUTING PROCESS GROUP

The purpose of the Executing Process Group is to carry out the work necessary to meet the project objectives. There are eight processes in the Executing Process Group.

- Direct and Manage Project Work
- Perform Quality Assurance
- Acquire Project Team
- Develop Project Team
- Manage Project Team
- Manage Communications
- Conduct Procurements
- Manage Stakeholder Engagement

The intent of the Executing Process Group is to at least:

- Create the deliverables
- Manage project quality
- Manage the project team
- Carry out project communications
- Report progress
- Manage changes
- Manage stakeholders
- Bid and award contracts

In these processes, the main work of the project is carried out and the majority of the funds are expended. To be effective, the project manager must coordinate project resources, manage changes, report progress, and manage stakeholders, while completing the project deliverables.

The forms used to document project execution include:

- Team Member Status Report
- Change Request
- Change Log
- Decision Log

## 136 Executing Forms

- Quality Audit
- Team Directory
- Team Operating Agreement
- Team Performance Assessment
- Team Member Performance Appraisal
- Issue Log

### 3.1 TEAM MEMBER STATUS REPORT

The Team Member Status Report is filled out by team members and submitted to the project manager on a regular basis. It tracks schedule and cost status for the current reporting period and provides planned information for the next reporting period. Status reports also identify new risks and issues that have arisen in the current reporting period. Typical information includes:

- Activities planned for the current reporting period
- Activities completed in the current reporting period
- Activities planned but not completed in the current reporting period
- Root causes of activities variances
- Funds spent in the current reporting period
- Funds planned to be spent for the current reporting period
- Root causes of funds variances
- Root causes of quality variances identified in the current reporting period
- Planned corrective or preventive action
- Activities planned for the next reporting period
- Costs planned for the next reporting period
- New risks identified
- Issues
- Comments

This information is generally compiled by the project manager into a Project Performance Report. The Team Member Status Report and the Project Performance Report are examples of work performance reports, an output of 9.4 Manage Project Team in the *PMBOK® Guide—Fifth Edition*.

You can use the element descriptions in Table 3.1 to assist you in developing a Team Member Status Report.

**TABLE 3.1 Elements of a Team Member Status Report**

Document Element	Description
Activities planned this reporting period	List all activities scheduled for this period, including work to be started, continued, or completed.
Activities accomplished this reporting period	List all activities accomplished this period, including work that was started, continued, or completed.
Activities planned but not accomplished this reporting period	List all activities that were scheduled for this period, but not started, continued, or completed.
Root cause of variances	For any work that was not accomplished as scheduled, identify the cause of the variance.
Funds spent this reporting period	Record funds spent this period.
Funds planned to be spent this reporting period	Record funds that were planned to be spent this period.
Root cause of funds variances	For any expenditures that were over or under plan, identify the cause of the variance. Include information on labor vs. material variances. Identify if the basis of estimates or the assumptions were inaccurate.
Quality variances identified this period	Identify any product performance or quality variances.
Planned corrective or preventive action	Identify any actions needed to recover cost, schedule, or quality variances or prevent future variances.

(Continued)

**TABLE 3.1** *(continued)*

<b>Document Element</b>	<b>Description</b>
Activities planned for next reporting period	List all activities scheduled for next period, including work to be started, continued, or completed.
Costs planned for next reporting period	Identify funds planned to be expended next period.
New risks identified	Identify any new risks that have arisen. New risks should be recorded in the Risk Register as well.
Issues	Identify any new issues that have arisen. New issues should be recorded in the Issue Log as well.
Comments	Document any comments that add relevance to this report.

# TEAM MEMBER STATUS REPORT

Project Title: \_\_\_\_\_ Date Prepared: \_\_\_\_\_

Team Member: \_\_\_\_\_ Role: \_\_\_\_\_

## Activities Planned for This Reporting Period

1.
2.
3.
4.
5.
6.

## Activities Accomplished This Reporting Period

1.
2.
3.
4.
5.
6.

## Activities Planned but Not Accomplished This Reporting Period

1.
2.
3.
4.

# TEAM MEMBER STATUS REPORT

Root Cause of Variances

--

Funds Spent This Reporting Period

--

Funds Planned to Be Spent This Reporting Period

--



# TEAM MEMBER STATUS REPORT

Root Cause of Variances

Quality Variances Identified This Period

Planned Corrective or Preventive Action

# TEAM MEMBER STATUS REPORT

## Activities Planned for Next Reporting Period

1.
2.
3.
4.
5.

## Costs Planned for Next Reporting Period

--

## New Risks Identified

Risk

## Issues

Issue

## Comments

--

### 3.2 CHANGE REQUEST

A Change Request is used to change any aspect of the project. It can pertain to project, product, documents, requirements, or any other aspect of the project. Upon completion, it is submitted to the Change Control Board or other similar body for review. Typical information includes:

- Person requesting the change
- An identifier, such as the change number
- Category of change
- Detailed description of the proposed change
- Justification for the proposed change
- Impacts of the proposed change
  - Scope
  - Quality
  - Requirements
  - Cost
  - Schedule
  - Project documents
- Disposition of change
- Justification
- Signatures of Change Control Board

The Change Request form can result from these processes:

- |   |  |
|---|--|
| <ul style="list-style-type: none"> <li>• Direct and Manage Project Work</li> <li>• Validate Scope</li> <li>• Control Schedule</li> <li>• Perform Quality Assurance</li> <li>• Manage Project Team</li> <li>• Control Risks</li> <li>• Conduct Procurements</li> <li>• Control Stakeholder Engagement</li> </ul> | <ul style="list-style-type: none"> <li>• Monitor and Control Project Work</li> <li>• Control Scope</li> <li>• Control Costs</li> <li>• Control Quality</li> <li>• Control Communications</li> <li>• Plan Procurement Management</li> <li>• Control Procurements</li> </ul> |
|---|--|

The Change Request form is related to:

- Change Log
- Change Management Plan

It provides information to the following process:

- Perform Integrated Change Control

You can use the element descriptions in Table 3.2 to assist you in developing a Change Request.

**TABLE 3.2 Elements of a Change Request**

Document Element	Description	
Category of change	Check a box to indicate the category of change.	
Detailed description of change	Describe the change proposal in enough detail to clearly communicate all aspects of the change.	
Justification for proposed change	Indicate the reason for the change.	
Impacts of change	Scope	Describe the impact of the proposed change on the project or product scope.
	Quality	Describe the impact of the proposed change on the project or product quality.
	Requirements	Describe the impact of the proposed change on the project or product requirements.
	Cost	Describe the impact of the proposed change on the project budget, cost estimates, or funding requirements.
	Schedule	Describe the impact of the proposed change on the schedule and whether it will cause a delay on the critical path.
	Project documents	Describe the impact of the proposed change on each project document.
Comments	Provide any comments that will clarify information about the requested change.	
Disposition	The Change Control Board (or other authority) determines whether the change is approved, deferred, or rejected.	
Justification	The Change Control Board provides a justification for the change request disposition.	

# CHANGE REQUEST

Project Title: \_\_\_\_\_ Date Prepared: \_\_\_\_\_

Person Requesting Change: \_\_\_\_\_ Change Number: \_\_\_\_\_

## Category of Change:

- Scope                       Quality                       Requirements  
 Cost                          Schedule                       Documents

## Detailed Description of Proposed Change

## Justification for Proposed Change

## Impacts of Change

<b>Scope</b>	<input type="checkbox"/> Increase	<input type="checkbox"/> Decrease	<input type="checkbox"/> Modify
Description:			
<b>Grade:</b>	<input type="checkbox"/> Increase	<input type="checkbox"/> Decrease	<input type="checkbox"/> Modify
Description:			

# CHANGE REQUEST

<b>Requirements</b>	<input type="checkbox"/> Increase	<input type="checkbox"/> Decrease	<input type="checkbox"/> Modify
Description:			
<b>Cost</b>	<input type="checkbox"/> Increase	<input type="checkbox"/> Decrease	<input type="checkbox"/> Modify
Description:			
<b>Schedule</b>	<input type="checkbox"/> Increase	<input type="checkbox"/> Decrease	<input type="checkbox"/> Modify
Description:			
<b>Stakeholder Impact</b>	<input type="checkbox"/> High risk	<input type="checkbox"/> Medium risk	<input type="checkbox"/> Low risk
Description:			
Project Documents			

## Comments

--

# CHANGE REQUEST

**Disposition**

Approve

Defer

Reject

**Justification**

--

**Change Control Board Signatures**

Name	Role	Signature

**Date:** \_\_\_\_\_

### 3.3 CHANGE LOG

The Change Log is a dynamic document that is kept throughout the project. It is used to track changes from request through final disposition. Typical information includes:

- Change ID
- Category
- Description of change
- Submitter
- Submission date
- Status
- Disposition

The Change Log is related to the:

- Change Request
- Change Management Plan

You can use the element descriptions in Table 3.3 to assist you in developing a Change Log.

**TABLE 3.3 Change Log**

Document Element	Description
Change ID	Enter a unique change identifier.
Category	Enter the category from the Change Request form.
Description of change	Describe the proposed change.
Submitted by	Enter the name of the person requesting the change.
Submission date	Enter the date the change was submitted.
Status	Enter the status as open, pending, closed.
Disposition	Enter the outcome of the Change Request as approved, deferred, or rejected.



# CHANGE LOG

Project Title: \_\_\_\_\_ Date Prepared: \_\_\_\_\_

Change ID	Category	Description of Change	Submitted by	Submission Date	Status	Disposition

### 3.4 DECISION LOG

The Decision Log is a dynamic document that is kept throughout the project. Frequently there are alternatives in developing a product or managing a project. Using a Decision Log can help keep track of the decisions that were made, who made them, and when they were made. A Decision Log can include:

- Identifier
- Category
- Decision
- Responsible party
- Date
- Comments

Use the information from your project to tailor the form to best meet your needs. You can use the element descriptions in Table 3.4 to assist you in developing a Decision Log.

**TABLE 3.4 Elements of a Decision Log**

<b>Document Element</b>	<b>Description</b>
ID	Enter a unique decision identifier.
Category	Enter the type of decision, such as technical, project, process, etc.
Decision	Provide a detailed description of the decision.
Responsible party	Identify the person authorized to make the decision.
Date	Include the date the decision was made and authorized.
Comments	Enter any further information to clarify the decision, alternatives considered, the reason the decision was made, and the impact of the decision.

# DECISION LOG

Project Title: \_\_\_\_\_ Date Prepared: \_\_\_\_\_

ID	Category	Decision	Responsible Party	Date	Comments

### 3.5 QUALITY AUDIT

A Quality Audit is a technique that employs a structured, independent review to project and/or product elements. Any aspect of the project or product can be audited. Common areas for audit include:

- Project processes
- Project documents
- Product requirements
- Product documents
- Implementation of approved changes
- Implementation of corrective or preventive action
- Defect or deficiency repair
- Compliance with organizational policies and procedures
- Compliance with the quality plan

Additional audit information can include:

- Good practices to share
- Areas for improvement
- Description of deficiencies or defects

Defects or deficiencies should include action items, a responsible party, and be assigned a due date for compliance. Audits should be tailored to best meet the needs of the project.

A Quality Audit is a technique from process 8.2, Perform Quality Assurance, in the *PMBOK® Guide—Fifth Edition*. Audits should be tailored to best meet the needs of the project. Results from the audit may necessitate a Change Request, including preventive or corrective action, and defect repair.

You can use the element descriptions in Table 3.5 to assist you in developing a document to support a quality audit.

**TABLE 3.5. Elements of a Quality Audit**

Document Element	Description	
Area audited	Check the box for the area or areas audited.	
Good practices to share	Describe any good or best practices that can be shared with other projects.	
Areas for improvement	Describe any areas that need improvement and the specific improvements or measurements that need to be achieved.	
Deficiencies or defects	ID	Enter a unique defect identifier.
	Defect	Describe the deficiency or defect.
	Action	Describe the corrective actions needed to fix the defect.
	Responsible party	Identify the person assigned to correct the deficiency or defect.
	Due date	Document the due date.
Comments	Provide any additional useful comments about the audit.	

# QUALITY AUDIT

Project Title: \_\_\_\_\_ Date Prepared: \_\_\_\_\_

Project Auditor: \_\_\_\_\_ Audit Date: \_\_\_\_\_

### Area Audited

<input type="checkbox"/> Project	<input type="checkbox"/> Project processes	<input type="checkbox"/> Project documents
<input type="checkbox"/> Product	<input type="checkbox"/> Product requirements	<input type="checkbox"/> Product documents
<input type="checkbox"/> Approved change implementation	<input type="checkbox"/> Corrective or preventive action implementation	<input type="checkbox"/> Defect/deficiency repair
<input type="checkbox"/> Quality Management Plan	<input type="checkbox"/> Organizational policies	<input type="checkbox"/> Organizational procedures

### Good Practices to Share

### Areas for Improvement

# QUALITY AUDIT

**Deficiencies or Defects**

ID	Defect	Action	Responsible Party	Due Date

**Comments**

### 3.6 TEAM DIRECTORY

The Team Directory lists the project team members and their primary contact information. It is particularly useful on virtual teams when team members often have not met one another and may work in different time zones. The contents of the Team Directory include:

- Name
- Role
- Department
- E-mail address
- Mobile and work phone numbers
- Work hours

Additional information can include the geographical location and organization that the individual works for. Use the information from your project to tailor the form to best meet your needs.

The Project Directory is compiled when team members are assigned and accompanies Project Staff Assignments, an output of 9.2 Acquire Team Members process.

You can use the element descriptions in Table 3.6 to assist you in developing a Team Directory.

**TABLE 3.6 Elements of a Team Directory**

Document Element	Description
Name	Record the name by which the person likes to be addressed.
Role	Identify the person’s role on the project team.
Department	List the functional department to which the person reports.
E-mail	Record the e-mail address.
Phone numbers	Enter the various phone numbers where the person can be reached.
Location	Document the location where the person works.
Work hours	Enter the work hours and time zone in which the person works.

# TEAM DIRECTORY

Project Title: \_\_\_\_\_

Date Prepared: \_\_\_\_\_

Name	Role	Department	E-mail	Phone Numbers (Mobile and Work)	Location	Work Hours



### 3.7 TEAM OPERATING AGREEMENT

The Team Operating Agreement is used to establish ground rules and guidelines for the team. It is particularly useful on virtual teams and teams that are comprised of members from different organizations. Using a Team Operating Agreement can help establish expectations and agreements on working effectively together. The contents of the Team Operating Agreement typically include:

- Team values and principles
- Meeting guidelines
- Communication guidelines
- Decision-making processes
- Conflict management approach

Additional information can be included as appropriate for the individual project and the individual team members. Use the information on your project to tailor the form to best meet your needs.

The Team Operating Agreement is generally part of Project Staff Assignments and is developed when team members are assigned through the 9.2 Acquire Team Members process.

You can use the element descriptions in Table 3.7 to assist you in developing a Team Operating Agreement.

**TABLE 3.7. Elements of a Team Operating Agreement**

Document Element	Description
Team values and principles	List values and principles by which the team agrees to operate. Examples include mutual respect, operating from fact not opinion, etc.
Meeting guidelines	Identify guidelines that will keep meetings productive. Examples include: decision makers must be present, start on time, stick to the agenda, etc.
Communication guidelines	List guidelines used for effective communication. Examples include: everyone voices their opinion, no dominating the conversation, no interrupting, no using inflammatory language, etc.
Decision-making process	Describe the process used to make decisions. Indicate the relative power of the project manager for decision making as well as any voting procedures. Also indicate the circumstances under which a decision can be revisited.
Conflict management approach	Describe the approach to managing conflict, when a conflict will be escalated, when it should be tabled for later discussion, etc.
Other agreements	List any other agreements or approaches to ensuring a collaborative and productive working relationship among team members.

# TEAM OPERATING AGREEMENT

Project Title: \_\_\_\_\_ Date Prepared: \_\_\_\_\_

## Team Values and Principles

<ol style="list-style-type: none"><li>1.</li><li>2.</li><li>3.</li><li>4.</li><li>5.</li></ol>
--

## Meeting Guidelines

<ol style="list-style-type: none"><li>1.</li><li>2.</li><li>3.</li><li>4.</li><li>5.</li></ol>
--

## Communication Guidelines

<ol style="list-style-type: none"><li>1.</li><li>2.</li><li>3.</li><li>4.</li><li>5.</li></ol>
--

## Decision-Making Process

--

# TEAM OPERATING AGREEMENT

## Conflict Management Approach

## Other Agreements

Signature:

---

---

---

---

---

---

---

---

---

---

Date:

---

---

---

---

---

---

---

---

---

---

### 3.8 TEAM PERFORMANCE ASSESSMENT

The Team Performance Assessment is used to review technical and interpersonal competencies of the team as a whole, as well as general characteristics such as team morale and cohesiveness. It is used by the project manager to identify areas to improve the team's ability to achieve agreed-upon project objectives. The contents of the Team Performance Assessment can include:

- Technical performance
  - Scope
  - Quality
  - Schedule
  - Cost
- Interpersonal competency
  - Communication
  - Collaboration
  - Conflict management
  - Decision making
- Team characteristics
  - Morale
  - Cohesiveness

This is just a sample of information that can be evaluated. Use the information from your project to tailor the form to best meet your needs.

The Team Performance Assessment provides information to the Manage Project Team process. It is an output of process 9.3 Develop Project Team in the *PMBOK® Guide—Fifth Edition*.

You can use the element descriptions in Table 3.8 to assist you in developing a Team Performance Assessment.

**TABLE 3.8 Elements of a Team Performance Assessment**

Document Element	Description	
Technical performance	Scope	Rate the team's ability to deliver the scope of the project and product. Provide comments that describe instances or aspects of scope performance that justify the rating.
	Quality	Rate the team's ability to deliver the quality required of the project and product. Provide comments that describe instances or aspects of quality performance that justify the rating.
	Schedule	Rate the team's ability to deliver on schedule. Provide comments that describe instances or aspects of schedule performance that justify the rating.
	Cost	Rate the team's ability to deliver within budget. Provide comments that describe instances or aspects of cost performance that justify the rating.

Document Element	Description	
Interpersonal competency	Communication	Rate the team's ability to communicate effectively. Provide comments that illustrate instances of communication that justify the rating.
	Collaboration	Rate the team's ability to collaborate effectively. Provide comments that illustrate instances of collaboration that justify the rating.
	Conflict management	Rate the team's ability to manage conflict effectively. Provide comments that illustrate instances of conflict management that justify the rating.
	Decision making	Rate the team's ability to make decisions effectively. Provide comments that illustrate instances of decision making that justify the rating.
Team morale	Describe the overall team morale.	
Areas for development	Area	List technical or interpersonal areas for development.
	Approach	Describe the development approach, such as training, mentoring, or coaching.
	Actions	List the actions necessary to implement the development approach.

# TEAM PERFORMANCE ASSESSMENT

Project Title: \_\_\_\_\_ Date Prepared: \_\_\_\_\_

## Technical Performance

<b>Scope</b>	<input type="checkbox"/> Exceeds Expectations	<input type="checkbox"/> Meets Expectations	<input type="checkbox"/> Needs Improvement
Comments:			
<b>Quality</b>	<input type="checkbox"/> Exceeds Expectations	<input type="checkbox"/> Meets Expectations	<input type="checkbox"/> Needs Improvement
Comments:			
<b>Schedule</b>	<input type="checkbox"/> Exceeds Expectations	<input type="checkbox"/> Meets Expectations	<input type="checkbox"/> Needs Improvement
Comments:			
<b>Cost</b>	<input type="checkbox"/> Exceeds Expectations	<input type="checkbox"/> Meets Expectations	<input type="checkbox"/> Needs Improvement
Comments:			

# TEAM PERFORMANCE ASSESSMENT

## Interpersonal Competency

<b>Communication</b>	<input type="checkbox"/> Exceeds Expectations	<input type="checkbox"/> Meets Expectations	<input type="checkbox"/> Needs Improvement
Comments:			
<b>Collaboration</b>	<input type="checkbox"/> Exceeds Expectations	<input type="checkbox"/> Meets Expectations	<input type="checkbox"/> Needs Improvement
Comments:			
<b>Conflict Management</b>	<input type="checkbox"/> Exceeds Expectations	<input type="checkbox"/> Meets Expectations	<input type="checkbox"/> Needs Improvement
Comments:			
<b>Decision Making</b>	<input type="checkbox"/> Exceeds Expectations	<input type="checkbox"/> Meets Expectations	<input type="checkbox"/> Needs Improvement
Comments:			

# TEAM PERFORMANCE ASSESSMENT

<b>Team Morale</b>	<input type="checkbox"/> Exceeds Expectations	<input type="checkbox"/> Meets Expectations	<input type="checkbox"/> Needs Improvement
--------------------	---	---	--

Comments:

## Areas for Development

Area	Approach	Actions



### 3.9 TEAM MEMBER PERFORMANCE ASSESSMENT

The Team Member Performance Assessment is used to review technical performance, interpersonal competencies, and strengths and weaknesses of individual team members. On many projects, the project manager does not provide formal team member assessment or evaluation. The performance assessment can be done very informally depending on the organization’s culture. The contents of the Team Member Performance Assessment can include:

- Technical performance
  - Scope
  - Quality
  - Schedule
  - Cost
- Interpersonal competency
  - Communication
  - Collaboration
  - Conflict management
  - Decision making
  - Leadership
- Strengths and weaknesses
- Areas for development

This is just a sample of information that can be evaluated. Use the information from your project to tailor the form to best meet your needs.

You can use the element descriptions in Table 3.9 to assist you in developing a Team Member Performance Assessment.

**TABLE 3.9 Elements of a Team Member Performance Assessment**

Document Element	Description
Technical performance	<p>Scope</p> <p>Rate the team member’s ability to deliver the scope of the project and product. Provide comments that describe instances or aspects of scope performance that justify the rating.</p>
	<p>Quality</p> <p>Rate the team member’s ability to deliver the quality required of the project and product. Provide comments that describe instances or aspects of quality performance that justify the rating.</p>
	<p>Schedule</p> <p>Rate the team member’s ability to deliver on schedule. Provide comments that describe instances or aspects of schedule performance that justify the rating.</p>
	<p>Cost</p> <p>Rate the team member’s ability to deliver within budget. Provide comments that describe instances or aspects of cost performance that justify the rating.</p>

*(continued)*

**TABLE 3.9. (continued)**

<b>Document Element</b>	<b>Description</b>	
Interpersonal competency	Communication	Rate the team member's ability to communicate effectively. Provide comments that illustrate instances of communication that justify the rating.
	Collaboration	Rate the team member's ability to collaborate effectively. Provide comments that illustrate instances of collaboration that justify the rating.
	Conflict management	Rate the team member's ability to manage conflict effectively. Provide comments that illustrate instances of conflict management that justify the rating.
	Decision making	Rate the team member's ability to make decisions effectively. Provide comments that illustrate instances of decision making that justify the rating.
	Leadership	Rate the team member's leadership ability. Provide comments that illustrate instances of leadership that justify the rating.
Strengths	Describe the team member's technical and interpersonal strengths. Give explicit examples.	
Weaknesses	Describe the team member's technical and interpersonal weaknesses. Give explicit examples.	
Areas for development	Area	List technical or interpersonal areas for development.
	Approach	Describe the development approach, such as training, mentoring, or coaching.
	Actions	List the actions necessary to implement the development approach.
Additional comments	Document any comments that provide additional insight or information into the team member's performance.	

# TEAM MEMBER PERFORMANCE ASSESSMENT

Project Title: \_\_\_\_\_ Date Prepared: \_\_\_\_\_

**Technical Performance**

<b>Scope</b>	<input type="checkbox"/> Exceeds Expectations	<input type="checkbox"/> Meets Expectations	<input type="checkbox"/> Needs Improvement
Comments:			
<b>Quality</b>	<input type="checkbox"/> Exceeds Expectations	<input type="checkbox"/> Meets Expectations	<input type="checkbox"/> Needs Improvement
Comments:			
<b>Schedule</b>	<input type="checkbox"/> Exceeds Expectations	<input type="checkbox"/> Meets Expectations	<input type="checkbox"/> Needs Improvement
Comments:			
<b>Cost</b>	<input type="checkbox"/> Exceeds Expectations	<input type="checkbox"/> Meets Expectations	<input type="checkbox"/> Needs Improvement
Comments:			

# TEAM MEMBER PERFORMANCE ASSESSMENT

**Interpersonal Competency**

<b>Communication</b>	<input type="checkbox"/> Exceeds Expectations	<input type="checkbox"/> Meets Expectations	<input type="checkbox"/> Needs Improvement
Comments:			
<b>Collaboration</b>	<input type="checkbox"/> Exceeds Expectations	<input type="checkbox"/> Meets Expectations	<input type="checkbox"/> Needs Improvement
Comments:			
<b>Conflict Management</b>	<input type="checkbox"/> Exceeds Expectations	<input type="checkbox"/> Meets Expectations	<input type="checkbox"/> Needs Improvement
Comments:			
<b>Decision Making</b>	<input type="checkbox"/> Exceeds Expectations	<input type="checkbox"/> Meets Expectations	<input type="checkbox"/> Needs Improvement
Comments:			
<b>Leadership</b>	<input type="checkbox"/> Exceeds Expectations	<input type="checkbox"/> Meets Expectations	<input type="checkbox"/> Needs Improvement
Comments:			

# TEAM MEMBER PERFORMANCE ASSESSMENT

**Strengths**

**Weaknesses**

**Areas for Development**

Area	Approach	Actions

**Additional Comments**

### 3.10 ISSUE LOG

The Issue Log is a project document used to document and monitor elements under discussion or in dispute between project stakeholders. It is a dynamic document that is kept throughout the project. An issue is a point or matter in question or in dispute, or a point or matter that is not settled and is under discussion, or over which there are opposing views or disagreements. Issues can also arise from a risk event that has occurred and must now be dealt with. An Issue Log includes:

- Identifier
- Category
- Issue
- Impact on objectives
- Responsible party
- Actions
- Status
- Due date
- Comments

Additional information can include the source of the issue and the urgency. Use the information from your project to tailor the form to best meet your needs.

The Issue Log is an output from process 13.3 Manage Stakeholder Engagement in the *PMBOK® Guide—Fifth Edition*.

You can use the element descriptions in Table 3.10 to assist you in developing an Issue Log.

**TABLE 3.10 Element of an Issue Log**

Document Element	Description
Issue ID	Enter a unique issue identifier.
Category	Document the category of issue, such as stakeholder issue, technical issue, decision, etc.
Issue	Provide a detailed description of the issue.
Impact on objectives	Identify the project objectives that the issue impacts and the degree of impact.
Urgency	Define the urgency as high, medium, or low.
Responsible party	Identify the person who is assigned to resolve the issue.
Actions	Document the actions needed to address and resolve the issue.
Status	Denote the status of the issue as open or closed.
Due date	Document the date by when the issue needs to be resolved.
Comments	Document any clarifying comments about the issue, resolution, or other fields on the form.

# ISSUE LOG

Project Title: \_\_\_\_\_ Date Prepared: \_\_\_\_\_

Issue ID	Category	Issue	Impact on Objectives	Urgency

Responsible Party	Actions	Status	Due Date	Comments





# Monitoring and Control Forms

## 4.0 MONITORING AND CONTROLLING PROCESS GROUP

The purpose of the Monitoring and Controlling Process Group is to review project work results and compare them to planned results. A significant variance indicates the need for preventive actions, corrective actions, or change requests. There are 11 processes in the Monitoring and Controlling Process Group:

- Monitor and control project work
- Perform integrated change control
- Validate scope
- Control scope
- Control schedule
- Control costs
- Control quality
- Control communications
- Control risks
- Control procurements
- Control stakeholder engagement

The intent of the Monitoring and Controlling Process Group is to at least:

- Review and analyze project performance
- Recommend changes and corrective and preventive actions
- Process Change Requests
- Report project performance
- Respond to risk events
- Manage contractors

Monitoring and controlling takes place throughout the project, from inception to closing. All variances are identified, and all Change Requests are processed here. The product deliverables are also accepted in the monitoring and controlling processes.

## 174 Monitoring and Control Forms

The forms used to document these activities include:

- Project Performance Report
- Variance Analysis
- Earned Value Status
- Risk Audit
- Contractor Status Report
- Product Acceptance

### 4.1 PROJECT PERFORMANCE REPORT

The Project Performance Report is filled out by the project manager and submitted on a regular basis to the sponsor, project portfolio management group, Project Management Office, or other project oversight person or group. The information is compiled from the Team Member Status Reports and also includes overall project performance. It contains summary-level information, such as accomplishments, rather than detailed activity-level information. The Project Performance Report tracks schedule and cost status for the current reporting period and provides planned information for the next reporting period. It indicates impacts to milestones and cost reserves as well as indentifying new risks and issues that have arisen in the current reporting period. Typical information includes:

- Accomplishments for the current reporting period
- Accomplishments planned but not completed in the current reporting period
- Root causes of accomplishment variances
- Impact to upcoming milestones or project due date
- Planned corrective or preventive action
- Funds spent in the current reporting period
- Root causes of budget variances
- Impact to overall budget or contingency funds
- Planned corrective or preventive action
- Accomplishments planned for the next reporting period
- Costs planned for the next reporting period
- New risks identified
- Issues
- Comments

You can use the element descriptions in Table 4.1 to assist you in developing a Project Performance Report.

**TABLE 4.1. Elements of a Project Performance Report**

Document Element	Description
Accomplishments for this reporting period	List all work packages or other accomplishments scheduled for completion for the current reporting period.
Accomplishments planned but not completed this reporting period	List all work packages or other accomplishments scheduled for the current period but not completed.
Root cause of variances	Identify the cause of the variance for any work that was not accomplished as scheduled for the current period.
Impact to upcoming milestones or project due date	Identify any impact to any upcoming milestones or overall project schedule for any work that was not accomplished as scheduled. Identify any work currently behind on the critical path or if the critical path has changed based on the variance.
Planned corrective or preventive action	Identify any actions needed to make up schedule variances or prevent future schedule variances.
Funds spent this reporting period	Record funds spent this period.
Root cause of variance	Identify the cause of the variance for any expenditure over or under plan. Include information on the labor variance versus material variance and whether the variance is due to the basis of estimates or estimating assumptions.

*(continued)*

**TABLE 4.1. (continued)**

Document Element	Description
Impact to overall budget or contingency funds	Indicate impact to the overall project budget or whether contingency funds must be expended.
Planned corrective or preventive action	Identify any actions needed to recover cost variances or to prevent future schedule variances.
Accomplishments planned for next reporting period	List all work packages or accomplishments scheduled for completion next period.
Costs planned for next reporting period	Identify funds planned to be expended next period.
New risks identified	Identify any new risks that have been identified this period. These risks should be recorded in the Risk Register as well.
Issues	Identify any new issues that have arisen this period. These issues should be recorded in the Issue Log as well.
Comments	Record any comments that add relevance to the report.

# PROJECT PERFORMANCE REPORT

Project Title: \_\_\_\_\_ Date Prepared: \_\_\_\_\_

Project Manager: \_\_\_\_\_ Sponsor: \_\_\_\_\_

## Accomplishments for This Reporting Period

<ol style="list-style-type: none"><li>1.</li><li>2.</li><li>3.</li><li>4.</li><li>5.</li><li>6.</li></ol>
---

## Accomplishments Planned but Not Completed This Reporting Period

<ol style="list-style-type: none"><li>1.</li><li>2.</li><li>3.</li><li>4.</li></ol>
---

## Root Cause of Variances

--

# PROJECT PERFORMANCE REPORT

Impact to Upcoming Milestones or Project Due Date

Planned Corrective or Preventive Action

Funds Spent This Reporting Period

Root Cause of Variances

# PROJECT PERFORMANCE REPORT

Impact to Overall Budget or Contingency Funds

Planned Corrective or Preventive Action

Accomplishments Planned for Next Reporting Period

- 1.
- 2.
- 3.
- 4.

Costs Planned for Next Reporting Period

# PROJECT PERFORMANCE REPORT

## New Risks Identified

Risk

## Issues

Issue

## Comments

--



## 4.2 VARIANCE ANALYSIS

Variance Analysis reports collect and assemble information on project performance variances. Common topics are schedule, cost, and quality variances. Information on a Variance Analysis includes:

- Schedule variance
  - Planned results
  - Actual results
  - Variance
  - Root cause
  - Planned response
- Cost variance
  - Planned results
  - Actual results
  - Variance
  - Root cause
  - Planned response
- Quality variance
  - Planned results
  - Actual results
  - Variance
  - Root cause
  - Planned response

Scope variance can be included but is generally indicated by a schedule variance, as more or less scope will have been accomplished over time. The Variance Analysis can be done at an activity, resource, work package, control account, or project level. It can be used to report project or product status to the project manager, the sponsor, or other stakeholders such as a vendor. Use the information from your project to tailor the form to best meet your needs.

You can use the element descriptions in Table 4.2 to assist you in developing a Variance Analysis.

**TABLE 4.2. Elements of a Variance Analysis**

Document Elements	Description
Schedule variance	<ul style="list-style-type: none"> <li>• Planned result Describe the work planned to be accomplished during the reporting period.</li> <li>• Actual result Describe the work actually accomplished during the reporting period.</li> <li>• Variance Describe the variance.</li> <li>• Root cause Identify the root cause of the variance.</li> <li>• Planned response Document the planned corrective or preventive action.</li> </ul>
Cost variance	<ul style="list-style-type: none"> <li>• Planned result Record the planned costs for the work planned to be accomplished during the reporting period.</li> <li>• Actual result Record the actual costs expended during the reporting period.</li> <li>• Variance Calculate the variance.</li> <li>• Root cause Identify the root cause of the variance.</li> <li>• Planned response Document the planned corrective or preventive action.</li> </ul>

*(continued)*

**TABLE 4.2. (continued)**

<b>Document Elements</b>	<b>Description</b>
Quality variance	<ul style="list-style-type: none"> <li data-bbox="407 321 1466 384">• Planned result      Describe the planned performance or quality measurements during the reporting period.</li> <li data-bbox="407 401 1466 464">• Actual result        Describe the actual performance or quality measurements during the reporting period.</li> <li data-bbox="407 480 1466 508">• Variance              Describe the variance.</li> <li data-bbox="407 525 1466 552">• Root cause            Identify the root cause of the variance.</li> <li data-bbox="407 569 1466 594">• Planned response    Document the planned corrective action.</li> </ul>

# VARIANCE ANALYSIS

Project Title: \_\_\_\_\_ Date Prepared: \_\_\_\_\_

## Schedule Variance

Planned Result	Actual Result	Variance
Root Cause		
Planned Response		

## Cost Variance

Planned Result	Actual Result	Variance

# VARIANCE ANALYSIS

Root Cause

Planned Response

Quality Variance

Planned Result	Actual Result	Variance

Root Cause

Planned Response

### 4.3 EARNED VALUE STATUS

An Earned Value Status report shows specific mathematical metrics that are designed to reflect the health of the project by integrating scope, schedule, and cost information. Information can be reported for the current reporting period and on a cumulative basis. Earned Value Status reports can also be used to forecast the total cost of the project at completion or the efficiency required to complete the project for the baseline budget. Information that is generally collected includes:

- Budget at completion (BAC)
- Planned value (PV)
- Earned value (EV)
- Actual cost (AC)
- Schedule variance (SV)
- Cost variance (CV)
- Schedule performance index (SPI)
- Cost performance index (CPI)
- Percent planned
- Percent earned
- Percent spent
- Estimates at completion (EAC)
- To complete performance index (TCPI)

Several different equations can be used to calculate the EAC depending on whether the remaining work will be completed at the budgeted rate or at the current rate. Two options are presented on this form. Similarly, there are various options to calculate a TCPI. Use the information from your project to determine the best approach for reporting. Information should reflect the most accurate historical data and assumptions for forecasts, and predictions should be documented and justified. Where appropriate, show the equations used to derive estimates.

Earned Value Status reports can be used as a technique in these processes:

- 4.4 Monitor and Control Project Work
- 6.7 Control Schedule
- 7.4 Control Costs
- 11.6 Control Risks
- 12.3 Control Procurements

You can use the element descriptions in Table 4.3 to assist you in developing an Earned Value Status report.

**TABLE 4.3. Elements of Earned Value Status**

Document Element	Description
Planned value	Enter the value of the work planned to be accomplished.
Earned value	Enter the value of the work actually accomplished.
Actual cost	Enter the cost for the work accomplished.
Schedule variance	Calculate the schedule variance by subtracting the planned value from the earned value: $SV = EV - PV$
Cost variance	Calculate the cost variance by subtracting the actual cost from the earned value: $CV = EV - AC$
Schedule performance index	Calculate the schedule performance index by dividing earned value by the planned value: $SPI = EV/PV$

*(continued)*

TABLE 4.3. (continued)

Document Element	Description
Cost performance index	Calculate the cost performance index by dividing the earned value by the actual cost: $CPI = EV/AC$
Root cause of schedule variance	Identify the root cause of the schedule variance.
Schedule impact	Describe the impact on deliverables, milestones, or critical path.
Root cause of cost variance	Identify the root cause of the cost variance.
Budget impact	Describe the impact on the project budget, contingency funds and reserves, and any intended actions to address the variance.
Percent planned	Indicate the cumulative percent of the work planned to be accomplished: $PV/BAC$
Percent earned	Indicate the cumulative percent of work that has been accomplished: $EV/BAC$
Percent spent	Indicate the cumulative percent of the budget that has been expended: $AC/BAC$
Estimates at completion	Determine an appropriate method to forecast the total expenditures at the project completion. Calculate the forecast and justify the reason for selecting the particular estimate at completion. For example:  If the CPI is expected to remain the same for the remainder of the project: $EAC = BAC / CPI$  If both the CPI and SPI will influence the remaining work: $EAC = AC + [(BAC - EV) / (CPI \times SPI)]$ .
To complete performance index	Calculate the work remaining divided by the funds remaining: $TCPI = (BAC - EV)/(BAC - AC)$ to complete on plan, or $TCPI = (BAC - EV)/(EAC - AC)$ to complete the current EAC

# EARNED VALUE STATUS REPORT

Project Title: \_\_\_\_\_ Date Prepared: \_\_\_\_\_

Budget at Completion (BAC): \_\_\_\_\_ Overall Status: \_\_\_\_\_

	Current Reporting Period	Current Period Cumulative	Past Period Cumulative
Planned value (PV)			
Earned value (EV)			
Actual cost (AC)			
Schedule variance (SV)			
Cost variance (CV)			
Schedule performance index (SPI)			
Cost performance index (CPI)			
<b>Root Cause of Schedule Variance:</b>			
<b>Schedule Impact:</b>			
<b>Root Cause of Cost Variance:</b>			
<b>Budget Impact:</b>			
Percent planned			
Percent earned			
Percent spent			
<b>Estimates at Completion (EAC):</b>			
EAC w/CPI [BAC/CPI]			
EAC w/ CPI*SPI [AC+((BAC-EV)/(CPI*SPI))]			
<b>Selected EAC, Justification, and Explanation</b>			
To complete performance index (TCPI)			

### 4.4 RISK AUDIT

Risk Audits are used to evaluate the effectiveness of the risk identification, risk responses, and risk management process as a whole. Information reviewed in a Risk Audit can include:

- Risk event audits
  - Risk events
  - Causes
  - Responses
- Risk response audits
  - Risk event
  - Responses
  - Success
  - Actions for improvement
- Risk management process
  - Process
  - Compliance
  - Tools and techniques used
- Good practices
- Areas for improvement

The Risk Audit is a tool used in process 11.6 Control Risks in the *PMBOK Guide*®—Fifth Edition. You can use the element descriptions in Table 4.4 to assist you in developing a Risk Audit.

**TABLE 4.4. Elements of a Risk Audit**

Document Elements	Description		
Risk event audit	<ul style="list-style-type: none"> <li>• Event</li> <li>• Cause</li> <li>• Response</li> <li>• Comment</li> </ul>	List the event from the Risk Register.	Identify the root cause of the event from the Risk Register.
Risk response audit	<ul style="list-style-type: none"> <li>• Event</li> <li>• Response</li> <li>• Successful</li> <li>• Actions to improve</li> </ul>	List the event from the Risk Register.	List the risk response from the Risk Register. Indicate if the response was successful. Identify any opportunities for improvement in risk response.
Risk management process audit	<ul style="list-style-type: none"> <li>• Risk Management Plan followed</li> </ul>	Indicate if the various processes were followed as indicated in the Risk Management Plan.	Tools and techniques used: Identify tools and techniques used in the various risk management processes and whether they were successful.
	<ul style="list-style-type: none"> <li>• Identify Risks</li> <li>• Perform Qualitative Risk Analysis</li> </ul>	Indicate if the processes were followed as indicated in the Risk Management Plan.	Indicate if the tools and techniques used in the processes were used and whether they were successful.



Document Elements	Description
Description of good practices to share	<ul style="list-style-type: none"><li>• Plan Risk Responses</li><li>• Control Risks</li></ul> <p>Describe any practices that should be shared for use on other projects. Include any recommendations to update and improve risk forms, templates, policies, procedures, or processes to ensure these practices are repeatable.</p>
Description of areas for improvement	Describe any practices that need improvement, the improvement plan, and any follow-up dates or information for corrective action.

# RISK AUDIT

Project Title: \_\_\_\_\_ Date Prepared: \_\_\_\_\_

Project Auditor: \_\_\_\_\_ Audit Date: \_\_\_\_\_

## Risk Event Audit

Event	Cause	Response	Comment

## Risk Response Audit

Event	Response	Successful	Actions to Improve

## Risk Management Process Audit

Process	Followed	Tools and Techniques Used
Plan Risk Management		
Identify Risks		
Perform Qualitative Assessment		
Perform Quantitative Assessment		
Plan Risk Responses		
Monitor and Control Risks		

# RISK AUDIT

Description of Good Practices to Share

Description of Areas for Improvement

## 4.5 CONTRACTOR STATUS REPORT

The Contractor Status Report is filled out by the contractor and submitted on a regular basis to the project manager. It tracks status for the current reporting period and provides forecasts for future reporting periods. The report also gathers information on new risks, disputes, and issues. Information can include:

- Scope performance
- Quality performance
- Schedule performance
- Cost performance
- Forecasted performance
- Claims or disputes
- Risks
- Preventive or corrective action
- Issues

This information is generally included in the Project Performance Report compiled by the project manager. You can use the element descriptions in Table 4.5 to assist you in developing a Contractor Status Report.

**TABLE 4.5. Elements of a Contractor Status Report**

Document Elements	Description
Scope performance this reporting period	Describe progress on scope made during this reporting period.
Quality performance this reporting period	Identify any quality or performance variances.
Schedule performance this reporting period	Describe whether the contract is on schedule. If ahead or behind, identify the cause of the variance.
Cost performance this reporting period	Describe whether the contract is on budget. If over or under budget, identify the cause of the variance.
Forecast performance for future reporting periods	Discuss the estimated delivery date and final cost of the contract. If the contract is a fixed price, do not enter cost forecasts.
Claims or disputes	Identify any new or resolved disputes or claims that have occurred during the current reporting period.
Risks	List any risks. Risks should also be in the Risk Register.
Planned corrective or preventive action	Identify planned corrective or preventive actions necessary to recover schedule, cost, scope, or quality variances.
Issues	Identify any new issues that have arisen. These should also be entered in the Issue Log.
Comments	Add any comments that will add relevance to the report.

# CONTRACTOR STATUS REPORT

Project Title: \_\_\_\_\_ Date Prepared: \_\_\_\_\_

Vendor: \_\_\_\_\_ Contract #: \_\_\_\_\_

**Scope Performance This Reporting Period**

**Quality Performance This Reporting Period**

**Schedule Performance This Reporting Period**

# CONTRACTOR STATUS REPORT

## Cost Performance This Reporting Period

## Forecast Performance for Future Reporting Periods

## Claims or Disputes

## Risks

# CONTRACTOR STATUS REPORT

**Planned Corrective or Preventive Action**

**Issues**

**Comments**

## 4.6 FORMAL ACCEPTANCE

The Formal Acceptance form is used to document acceptance by the customer or other stakeholder. Formal Acceptance can be done periodically throughout the project, as with partial or interim deliverables, or for the project as a whole.

There are two aspects regarding the deliverables' formal acceptance:

1. Verify the correctness of the deliverable; this is performed during the Control Quality process.
2. Validate that the verified deliverable meets the acceptance criteria agreed upon with the customer; this is performed during Validate Scope.

Deliverables that meet the acceptance criteria are formally signed off and approved by the customer or sponsor. This formal documentation is forwarded to the Close Project or Phase process (Section 4.6).

The Formal Acceptance form may include, but is not limited to:

- Requirements
- Method of validation
- Acceptance criteria
- Status of deliverable
- Signoff

Use the information from your project to tailor the form to best meet your needs.

The Formal Acceptance form can receive information from:

- Project Management Plan
- Requirements Documentation
- Requirements Traceability Matrix
- Work Performance Data

It provides information to:

- Project Performance Reports
- Change Requests
- Project Closeout Report

This form can be used in conjunction with processes 8.3 Control Quality and 5.5 Validate Scope in the *PMBOK Guide*®—Fifth Edition.

You can use the element descriptions in Table 4.6 to assist you in developing a Product Acceptance report.

**TABLE 4.6. Elements of Product Acceptance**

Document Elements	Description
ID	Enter a unique requirement identifier from the requirements documentation.
Requirement	Enter the requirement description from the requirements documentation.
Acceptance criteria	Enter the criteria for acceptance from the requirements documentation.
Validation method	Describe the method of validating that the requirement meets the stakeholder's needs.
Status	Document whether the requirement or deliverable was accepted or not.
Comments	Document why the requirement or deliverable was <i>not</i> accepted and the required changes for being accepted.
Signoff	Obtain the signature of the party accepting the product.



# FORMAL ACCEPTANCE FORM

Project Title: \_\_\_\_\_ Date Prepared: \_\_\_\_\_

ID	Requirement	Acceptance Criteria	Validation Method	Status	Comments	Signoff



# Closing

## 5.0 CLOSING PROCESS GROUP

The purpose of the Closing Process Group is to complete contracts, project work, product work, and project phases in an orderly manner. There are two processes in the Closing Process Group:

- Close project or phase
- Close procurements

The intent of the Closing Process Group is to at least:

- Close all contracts
- Close project phases
- Document lessons learned
- Document final project results
- Archive project records

As the final processes in the project, the closing processes ensure an organized and efficient completion of deliverables, phases, and contracts.

The forms used to document project closure include:

- Procurement Audit
- Contract Close-Out
- Project Close-Out
- Lessons Learned

## 5.1 PROCUREMENT AUDIT

The Procurement Audit is the review of contracts and contracting processes for completeness, accuracy and effectiveness. Information in the audit can be used to improve the process and results on the current procurement or on other contracts. Information recorded in the audit includes:

- Vendor performance audit
  - Scope
  - Quality

- Schedule
- Cost
- Other information, such as how easy the vendor was to work with
- Procurement management process audit
  - Process
  - Tools and techniques used
- Description of good practices
- Description of areas for improvement

The Procurement Audit can receive information from:

- Project Management Plan

Procurement Audit information can be used to collect information for Lessons Learned. The information can be combined with the Contract Close-Out report or used separately. Use the information from your project to determine the best approach.

The Procurement Audit is a technique from process 12.4 Close Procurements in the *PMBOK® Guide—Fifth Edition*.

You can use the element descriptions in Table 5.1 to assist you in developing a Procurement Audit.

**TABLE 5.1. Elements of a Procurement Audit**

Document Elements	Description
What worked well	<ul style="list-style-type: none"> <li>• Scope Describe aspects of contract scope that were handled well.</li> <li>• Quality Describe aspects of product quality that were handled well.</li> <li>• Schedule Describe aspects of the contract schedule that were handled well.</li> <li>• Cost Describe aspects of the contract budget that were handled well.</li> <li>• Other Describe any other aspects of the contract or procurement that were handled well.</li> </ul>
What can be improved	<ul style="list-style-type: none"> <li>• Scope Describe aspects of contract scope that could be improved.</li> <li>• Quality Describe aspects of product quality that could be improved.</li> <li>• Schedule Describe aspects of the contract schedule that could be improved.</li> <li>• Cost Describe aspects of the contract budget that could be improved.</li> <li>• Other Describe any other aspects of the contract or procurement that could be improved.</li> </ul>
Procurement management process audit	<ul style="list-style-type: none"> <li>• Plan procurements Indicate if each process was followed or not Describe any tools or techniques that were effective for the process.</li> <li>• Conduct procurements</li> <li>• Control procurements</li> <li>• Close procurements</li> </ul>
Good practices to share	Describe any good practices that can be shared with other projects or that should be incorporated into organization policies, procedures, or processes. Include information on Lessons Learned.
Areas for improvement	Describe any areas that should be improved with the procurement process. Include information that should be incorporated into policies, procedures, or processes. Include information on Lessons Learned.

# PROCUREMENT AUDIT

Project Title: \_\_\_\_\_ Date Prepared: \_\_\_\_\_

Project Auditor: \_\_\_\_\_ Audit Date: \_\_\_\_\_

## Vendor Performance Audit

What Worked Well	
Scope	
Quality	
Schedule	
Cost	
Other	
What Can Be Improved	
Scope	
Quality	
Schedule	
Cost	
Other	

## Procurement Management Process Audit

Process	Followed	Tools and Techniques Used
<i>Plan Procurements</i>		
<i>Conduct Procurements</i>		
<i>Administer Procurements</i>		
<i>Close Procurements</i>		

# PROCUREMENT AUDIT

Description of Good Practices to Share

Description of Areas for Improvement

## 5.2 CONTRACT CLOSE-OUT

Contract close-out involves documenting the vendor performance so that the information can be used to evaluate the vendor for future work. Contract closure supports the project closure process and helps ensure contractual agreements are completed or terminated. Before a contract can be fully closed or terminated, all disputes must be resolved, the product or result must be accepted, and the final payments must be made. Information recorded as part of closing out a contract includes:

- Vendor performance analysis
  - Scope
  - Quality
  - Schedule
  - Cost
  - Other information, such as how easy the vendor was to work with
- Record of contract changes
  - Change ID
  - Description of change
  - Date approved
- Record of contract disputes
  - Description of dispute
  - Resolution
  - Date resolved

The date of contract completion, who signed off on it, and the date of the final payment are other elements that should be recorded.

The Contract Close-Out report can be combined with the Procurement Audit report. This information can be used in the Lessons Learned document and the Project Close-out report. Use the information from your project to determine the best approach.

You can use the element descriptions in Table 5.2 to assist you in developing a Contract Close-Out.

**TABLE 5.2 Elements of a Contract Close-Out**

Document Elements	Description	
What worked well	• Scope	Describe aspects of contract scope that were handled well.
	• Quality	Describe aspects of product quality that were handled well.
	• Schedule	Describe aspects of the contract schedule that were handled well.
	• Cost	Describe aspects of the contract budget that were handled well.
	• Other	Describe any other aspects of the contract or procurement that were handled well.
What can be improved	• Scope	Describe aspects of contract scope that could be improved.
	• Quality	Describe aspects of product quality that could be improved.
	• Schedule	Describe aspects of the contract schedule that could be improved.
	• Cost	Describe aspects of the contract budget that could be improved.
	• Other	Describe any other aspects of the contract or procurement that could be improved.
Record of contract changes	• Change ID	Enter the change identifier from the change log.
	• Change description	Enter the description from the change log.
	• Date approved	Enter the date approved from the change log.
Record of contract disputes	• Description	Describe the dispute or claim.
	• Resolution	Describe the resolution.
	• Date resolved	Enter the date the dispute or claim was resolved.



# CONTRACT CLOSE-OUT

Project Title: \_\_\_\_\_ Date Prepared: \_\_\_\_\_

Project Manager: \_\_\_\_\_ Contract Representative: \_\_\_\_\_

## Vendor Performance Analysis

What Worked Well:	
Scope	
Quality	
Schedule	
Cost	
Other	
What Can Be Improved:	
Scope	
Quality	
Schedule	
Cost	
Other	

## Record of Contract Changes

Change ID	Change Description	Date Approved

# CONTRACT CLOSE-OUT

## Record of Contract Disputes

Description	Resolution	Date Resolved

Date of Contract Completion \_\_\_\_\_

Signed Off by \_\_\_\_\_

Date of Final Payment \_\_\_\_\_

### 5.3 PROJECT OR PHASE CLOSE-OUT

Project Close-Out involves documenting the final project performance as compared to the project objectives. The objectives from the Project Charter are reviewed and evidence of meeting them is documented. If an objective was not met, or if there is a variance, that is documented as well. In addition, information from the Procurement Close-Out is documented. Information documented includes:

- Project or phase description
- Project or phase objectives
- Completion criteria
- How met
- Variances
- Contract information
- Approvals

The Project Close-Out can receive information from:

- Project Management Plan
- Product Acceptance Form

When working with an incremental life cycle or agile processes, the end of a development cycle or phase may result in the delivery of a major end item, service or capability. In this case a formal project or phase close out report should be considered. Use the information from your project to determine the best approach.

The Project or Phase Close-Out process report is related to the Contract Close-Out report and the Lessons Learned documentation. This information can be combined for smaller projects.

The Project Close-Out form supports process 4.6 Close Project or Phase in the *PMBOK® Guide—Fifth Edition*.

You can use the element descriptions in Table 5.3 to assist you in developing a Project Close-Out.

**TABLE 5.3. Elements of a Project Close-Out**

Document Elements	Description
Project or phase description	Provide a summary level description of the project. This information can be copied from the Project Charter. In the case of an incremental development effort, treat each phase of a project as a completed “mini-project” within the overall project development effort. Incremental development efforts could be part of an agile process or a major phase within an incremental project development lifecycle.
Performance summary	<ul style="list-style-type: none"> <li data-bbox="407 506 1469 695">• Scope Describe the scope objectives needed to achieve the planned benefits of the project or phase.  Document the specific and measureable criteria needed to complete the scope objectives.  Provide evidence that the completion criteria was met.</li> <li data-bbox="407 722 1469 947">• Quality Describe the quality objectives and criteria needed to achieve the planned benefits of the project or phase.  Document the specific and measureable criteria needed to meet the product and project or phase quality objectives.  Enter the verification and validation information from the Product Acceptance form.</li> <li data-bbox="407 974 1469 1157">• Schedule Describe the schedule objective needed to achieve the timely completion of the project.  Document the specific dates that needed to be met to meet the schedule objectives. This may include milestone delivery dates.  Identify the date of deliverable deliveries.</li> <li data-bbox="407 1184 1469 1346">• Cost Describe the cost objective needed to achieve the planned expenditures for the project or phase.  Document the specific amount or range that indicates budgetary success.  Enter the final project or phase costs.</li> </ul>
Variance information	Document and explain any variance information from any of the project or phase objectives.
Contract information	Provide information on contract performance. Enter information from the Contract Close-Out report, or refer to it and provide directions on how to access the information.

# PROJECT CLOSE-OUT

Project Title: \_\_\_\_\_

Date Prepared: \_\_\_\_\_

Project Manager: \_\_\_\_\_

Project Description

# PROJECT CLOSE-OUT

## Performance Summary

	Project Objectives	Completion Criteria	How Met
Scope			
Quality			
Time			
Cost			

## 5.4 LESSONS LEARNED

Lessons learned can be compiled throughout the project or at specific intervals, such as the end of a lifecycle phase. The purpose of gathering Lessons Learned is to identify those things that the project team did that worked very well and should be passed along to other project teams and to identify those things that should be improved for future project work. Lessons learned can be project oriented or product oriented. They should include information on risks, issues, procurements, quality defects, and any areas of poor or outstanding performance. Information that can be documented includes:

- Project performance analysis
  - Requirements
  - Scope
  - Schedule
  - Cost
  - Quality
  - Human resources
  - Communication
  - Stakeholder management
  - Reporting
  - Risk management
  - Procurement management
  - Process improvement
  - Product-specific information
- Information on specific risks
- Quality defects
- Vendor management
- Areas of exceptional performance
- Areas for improvement

This information is used to improve performance on the current project (if done during the project) and future projects. Use the information from your project to tailor the form to best meet your needs.

The Lessons Learned form supports process 4.6 Close Project or Phase in the *PMBOK® Guide—Fifth Edition*.

**You can use the element descriptions in Table 5.4 to assist you in compiling Lessons Learned. Table 5.4. Elements of Lessons Learned**

Document Elements	Description	
<b>Project Performance</b>	<b>What Worked Well</b>	<b>What Can Be Improved</b>
Requirements definition and management	List any practices or incidents that were effective in defining and managing requirements.	List any practices or incidents that can be improved in defining and managing requirements.
Scope definition and management	List any practices or incidents that were effective in defining and managing scope.	List any practices or incidents that can be improved in defining and managing scope.
Schedule development and control	List any practices or incidents that were effective in developing and controlling the schedule.	List any practices or incidents that can be improved in developing and controlling the schedule.

(continued)

(continued)

Document Elements	Description	
Project Performance	What Worked Well	What Can Be Improved
Cost estimating and control	List any practices or incidents that were effective in developing estimates and controlling costs.	List any practices or incidents that can be improved in developing estimates and controlling costs.
Quality planning and control	List any practices or incidents that were effective in planning, assuring, and controlling quality. Specific defects are addressed elsewhere.	List any practices or incidents that can be improved in planning, assuring, and controlling quality. Specific defects are addressed elsewhere.
Human resource availability, team development, and performance	List any practices or incidents that were effective in working with team members and developing and managing the team.	List any practices or incidents that can be improved in working with team members and developing and managing the team.
Communication management	List any practices or incidents that were effective in planning and distributing information.	List any practices or incidents that can be improved in planning and distributing information.
Stakeholder management	List any practices or incidents that were effective in managing stakeholder expectations.	List any practices or incidents that can be improved in managing stakeholder expectations.
Reporting	List any practices or incidents that were effective in reporting project performance.	List any practices or incidents that can be improved in reporting project performance.
Risk management	List any practices or incidents that were effective in the risk management process. Specific risks are addressed elsewhere.	List any practices or incidents that can be improved in the risk management process. Specific risks are addressed elsewhere.
Procurement planning and management	List any practices or incidents that were effective in planning, conducting, and administering contracts.	List any practices or incidents that can be improved in planning, conducting, and administering contracts.
Process improvement information	List any processes that were developed that should be continued.	List any processes that should be changed or discontinued.
Product-specific information	List any practices or incidents that were effective in delivering the specific product, service, or result.	List any practices or incidents that can be improved in delivering the specific product, service, or result.
Other	List any other practices or incidents that were effective, such as change control, configuration management, etc.	List any other practices or incidents that can be improved, such as change control, configuration management, etc.



<b>Document Elements</b>	<b>Description</b>	
<b>Project Performance</b>	<b>What Worked Well</b>	<b>What Can Be Improved</b>
Risks and issues	<ul style="list-style-type: none"> <li>• Risk or issue description</li> <li>• Response</li> <li>• Comments</li> </ul>	<p>Identify risks or issues that occurred that should be considered to improve organizational learning.</p> <p>Describe the response and its effectiveness.</p> <p>Provide any additional information needed to improve future project performance.</p>
Quality defects	<ul style="list-style-type: none"> <li>• Defect description</li> <li>• Resolution</li> <li>• Comments</li> </ul>	<p>Describe quality defects that should be considered in order to improve organizational effectiveness.</p> <p>Describe how the defects were resolved.</p> <p>Indicate what should be done to improve future project performance.</p>
Vendor management	<ul style="list-style-type: none"> <li>• Vendor</li> <li>• Issue</li> <li>• Resolution</li> <li>• Comments</li> </ul>	<p>List the vendor</p> <p>Describe any issues, claims, or disputes that occurred.</p> <p>Describe the outcome or resolution.</p> <p>Indicate what should be done to improve future vendor management performance.</p>
Other	<ul style="list-style-type: none"> <li>• Areas of exceptional performance</li> <li>• Areas for improvement</li> </ul>	<p>Identify areas of exceptional performance that can be passed on to other teams.</p> <p>Identify areas that can be improved on for future performance.</p>

# LESSONS LEARNED

Project Title: \_\_\_\_\_

Date Prepared: \_\_\_\_\_

## Project Performance Analysis

	What Worked Well	What Can Be Improved
Requirements definition and management		
Scope definition and management		
Schedule development and control		
Cost estimating and control		
Quality planning and control		
Human resource availability, team development, and performance		
Communication management		
Stakeholder management		
Reporting		
Risk management		
Procurement planning and management		
Process improvement information		
Product-specific information		
Other		

# LESSONS LEARNED

## Risks and Issues

Risk or Issue Description	Response	Comments

## Quality Defects

Defect Description	Resolution	Comments

## Vendor Management

Vendoer	Issue	Resolution	Comments

## Other

Areas of Exceptional Performance	Areas for Improvement



# Index

## A

Accepted Deliverables, information provision, 40

Activity Attributes, 48–50

Activity List, relationship, 48

elements, 49t

form

example, 50

usage, 14

information provision, 43, 48

Milestone List, relationship, 48

Activity Cost Estimates, 71–72

elements, 71t

form

example, 72

usage, 14

information, provision, 40, 65, 71

Activity Duration Estimates, 59–60

elements, 59t

form

example, 60

usage, 14

information

provision, 59, 61

usage, 33, 36, 43, 46, 57

types, 59

Activity Duration Estimating Worksheet, elements,

62t–63t

Activity List, 46–47

Activity Attributes, relationship, 46

elements, 46t

form

example, 47

usage, 14

information provision, 40, 43, 48

Milestone List, relationship, 46, 48, 51

Activity name, display, 65

Activity Resource Requirements, 55–56

form

elements, 55t

example, 56

usage, 14

information provision, 43, 46, 48, 55

Resource Breakdown Structure, relationship, 57  
resources, 55

Actual cost (AC), 186

Agile process, usage, 207

Agreements (contracts), information provision, 78

Analogous estimates, 59, 73

derivation, 61

elements, 62t, 74t

Assumption and Constraint Log, 36–37

form

example, 37

usage, 14

information provision, 36, 48

Assumption log

elaboration, 33

elements, 36t

Audit information, 152

## B

Beta Distribution, 61

Bottom-Up Cost Estimating Worksheet

elements, 75t

form

example, 77

usage, 14

Bottom-up estimates, usage, 73

Budget at completion (BAC), 186

## C

Change Log, 135, 148–149

Change Request form, relationship, 143

elements, 148t

form, example, 149

information, 148

relationships, 148

Change Management Plan, 132–133

Change Log, relationship, 132, 148

Change Request form, relationship, 132, 143

elements, 132t–133t

form, usage, 15

inclusion, 16

Change management process, 132

- Change Request, 135, 143–147
    - Change Log, relationship, 148
    - Change Management Plan, relationship, 143, 148
    - elements, 144t
    - form
      - example, 145–147
      - relationship, 143
      - result, 143
    - information, 143
    - provision, 29, 46, 51
  - Close Phase process, 197
  - Close Project phase, 197
  - Closing Process Group, 199
    - intent, 199
    - processes, 199
  - Collect Requirements, process, 13
  - Communications Management Plan, 102–103
    - elements, 102t
    - form
      - example, 103
      - usage, 14
    - inclusion, 16
    - information, 102
    - source, 8, 102
    - usage, 129
  - Configuration Management Plan, inclusion, 16
  - Contract changes, record, 203
  - Contract Close-Out, 199, 203–206
    - elements, 204t
    - form, example, 205–206
    - information, 203
    - report, combination, 200, 203
  - Contract disputes, record, 203
  - Contractor Status Report, 174, 193–196
    - elements, 193t
    - form, example, 194–196
    - information, 193
  - Control forms, 173
  - Cost Baseline, 78–79
    - example, 79
    - form, usage, 14
    - information, provision, 70, 78
  - Cost Estimating Worksheet, 73–77
    - Bottom-Up Cost Estimating Worksheet
      - elements, 75t
      - form, example, 77
    - elements, 74t
    - estimated cost, equation, 73
    - form
      - example, 76
      - usage, 14
    - information, provision, 73
    - quantitative methods, 73
    - usage, 71
  - Cost Management Plan, 68–69
    - elements, 68t–69t
    - form, usage, 14
    - inclusion, 16
    - information, 2
    - provision, 68
  - Cost performance, 193
  - Cost performance index (CPI), 186
  - Cost variance (CV), 182, 186
  - Create WBS, process, 13
- D**
- Decision Log, 135, 150–151
    - components, 150
    - elements, 150
    - form, example, 151
  - Define Activities, process, 13
  - Define Scope, process, 13
  - Determine Budget, process, 13
  - Develop Project Management Plan, process, 13
  - Develop Schedule, process, 13
  - Duration estimates
    - accuracy, improvement, 61
    - equation, 61
  - Duration Estimating Worksheet, 61–63
    - Beta Distribution, 61
    - form, 64
    - information provision, 55, 61
- E**
- Earned value (EV), 186
  - Earned Value Status, 174, 186–188
    - elements, 186t–187t
    - information, 186
    - Report, example, 188
  - Estimate Activity Durations, process, 13
  - Estimate Activity Resources, process, 13
  - Estimate Costs, process, 13
  - Estimated cost, equation, 73
  - Estimated duration, equation, 61
  - Estimates at completion (EAC), 186
  - Executing forms, 135
  - Executing Process Group, 135–136
    - intent, 135
    - processes, 135

**F**

Finish dates, display, 65  
 Finish-to-finish (FF), network diagram relationship, 53  
 Finish-to-start (FS), network diagram relationship, 53  
 Forecasted performance, 193  
 Formal acceptance, 197–198  
   form  
     components, 197  
     example, 198  
     information, 197  
     product acceptance, elements, 197

**G**

Gantt chart  
   components, 65  
   information provision, 46, 51, 57  
   sample, 64, 66  
 Geography, 38

**H**

Human Resource Management Plan,  
   inclusion, 16  
 Human Resource Plan, 96–99  
   elements, 97t  
   form  
     example, 98–99  
     usage, 14  
   information  
     provision, 55, 93  
     source, 96  
   sections, 96

**I**

Identify Risks, process, 13  
 Initiating forms, 1  
 Initiating information, documentation form, 1  
 Initiating process group, purpose, 1  
 Inter-Requirements Traceability Matrix  
   elements, 30t  
   form, example, 32t  
   usage, 29  
 Issue Log, 136, 170–171  
   components, 170  
   elements, 170t  
   form, example, 171

**L**

Lags, 53  
 Leads, 53

Lessons Learned, 199, 211–215  
   elements, 211–213  
   form, example, 214–215  
   purpose, 211  
 Life cycle phases, 38  
 Life cycle process, usage, 207

**M**

Major deliverables, 38  
 Make-or-Buy Decisions, information provision, 71  
 Milestone Chart  
   creation, 65  
   sample, 67  
 Milestone List, 51–52  
   Activity List, relationship, 46, 51  
   elements, 51t  
   form  
     example, 52  
     usage, 14  
   information provision, 51  
 Monitoring and Controlling Process Group, 173–174  
   documentation, forms (usage), 174  
   intent, 173  
   processes, 173  
 Monitoring forms, 173

**N**

Network Diagram, 53–54  
   flowchart, 54  
   form, usage, 14  
   information  
     provision, 52  
     usage, 33, 36, 43, 46, 48, 51  
   relationships, 53

**P**

Parametric estimates, 59, 61, 73  
   elements, 62t, 74t  
 Percent planned/earned/spent, 186  
 Perform Qualitative Analysis, process, 13  
 Perform Quantitative Analysis, process, 13  
 Phase Close-Out, 207  
 Plan Communication Management, process, 13  
 Plan Cost Management, process, 13  
 Plan Human Resource Management, process, 13  
 Planned value (PV), 186  
 Planning forms, 13  
 Planning process group, 13–15  
   intent, 13–14  
 Plan Procurement Management, process, 13  
 Plan Quality, process, 13

- Plan Risk Management, process, 13
- Plan Risk Responses, process, 13
- Plan Schedule Management, process, 13
- Plan Scope Management, process, 13
- Plan Stakeholder Management, process, 13
- Plan Stakeholder Management Plan, elements, 129t
- Probability and Impact Assessment, 112–116
  - elements, 112t–114t
  - form
    - example, 115–116
    - usage, 14
- Probability and Impact Matrix, 117–118
  - form
    - example, 118
    - usage, 15
  - information source, 117
- Process Improvement Plan, 85–90
  - components, 85
  - elements, 86t–87t
  - form
    - example, 88–90
    - usage, 14
  - inclusion, 16
  - information source, 85
  - Quality Management Plan, relationship, 80, 85
  - Quality Metrics, relationship, 83, 85
- Procurement Audit, 199–202
  - elements, 200t
  - form, example, 201–202
  - information, 199–200
  - source, 200
- Procurement documents, information source, 11
- Procurement Management Plan, 122–126
  - elements, 123t
  - form
    - example, 124–126
    - usage, 15
  - inclusion, 16
  - information, 122
    - provision, 40, 55, 65
    - source, 8, 27, 122
  - integration, information, 122
- Procurement management process audit, 200
- Product Acceptance, 174
  - elements, 197
  - information provision, 29
- Project
  - authorization, 1
  - closure (documentation), forms (usage), 199
  - cost baselines, 78
    - execution (documentation), forms (usage), 135–136
    - performance, analysis, 211
  - Project Budget, information provision, 40, 65
  - Project Charter, 2–7
    - elements, 2t–3t
    - form
      - example, 4–7
      - usage, 1
    - information source, 2, 11, 23
  - Project Charter, information source, 20
  - Project Close-Out, 199, 207–210
    - elements, 208t
    - form, example, 209–210
    - information, 207
  - Project Management Plan, 16–19
    - elements, 17t
    - form
      - example, 18–19
      - usage, 14
    - information, 2, 16, 200
    - provision, 78, 197
    - source, 16, 20
    - Requirements Management Plan, relationship, 20
  - Project Organization Charts, 96
  - Project Performance Report, 174, 175–181
    - elements, 175t–176t
    - form, example, 177–181
    - information, 175
  - Project Schedule, 65–67
    - Gantt Chart, sample, 66
    - information provision, 33, 36, 43, 53, 55, 59
    - Milestone Chart, sample, 67
  - Project Scope Statement, 33–35
    - elements, 34t
    - form
      - example, 35
      - usage, 14
    - information, 2, 33
    - provision, 33, 51, 65
- Q**
  - Quality assurance, approach, 80
  - Quality Audit, 136, 152–154
    - areas, examination, 152
    - audit information, 152
    - elements, 152
    - form, example, 153–154
  - Quality control, approach, 80
  - Quality defects, 211
  - Quality improvement, approach, 80



- Quality Management Plan, 80–82
    - elements, 80t
    - form
      - example, 81–82
      - usage, 14
    - inclusion, 16
    - information
      - components, 80
      - provision, 80
      - source, 8, 27
    - Process Improvement Plan, relationship, 80, 85
    - Quality Metrics, relationship, 80, 83
  - Quality Metrics, 83–84
    - elements, 83t
    - form
      - example, 84
      - usage, 14
    - information source, 83
    - Process Improvement Plan, relationship, 83, 85
    - Quality Management Plan, relationship, 80, 83
  - Quality performance, 193
  - Quality variance, 182
- R**
- RACI. *See* Responsible, Accountable, Consulted, Informed
  - RAM. *See* Responsibility Assignment Matrix
  - Requirements Documentation, 27–28
    - elements, 27t
    - form
      - example, 28
      - usage, 14
    - information, 2
      - provision, 23
      - source, 8, 20, 27
      - usage, 129, 197
    - Requirements Traceability Matrix, relationship, 27
  - Requirements Management Plan, 23–26
    - elements, 25t
    - form
      - example, 25–26
      - usage, 14
    - inclusion, 16
    - information, 2
      - Scope Management Plan, relationship, 23
  - Requirements Traceability Matrix, 29–32
    - elements, 29t–30t
    - form
      - example, 31t
      - usage, 14
    - information, 2
      - provision, 23, 197
      - source, 29
    - Requirements Documentation, relationship, 29
  - Resource Breakdown Structure, 57–58
    - Activity Resource Requirements, relationship, 57
    - form, usage, 14
    - information, provision, 43, 55
    - outline, 58
  - Resource calendars, 96
  - Resource name, display, 65
  - Responsibility Assignment Matrix (RAM), 91–92
    - elements, 91t
    - form
      - example, 92
      - usage, 14
    - information source, 91
    - resource role description, relationship, 91
    - Roles and Responsibilities, relationship, 93
  - Responsible, Accountable, Consulted, Informed (RACI) chart, usage, 91
  - Rewards and recognition, 96
  - Risk Audit, 174, 189–192
    - elements, 189t–190t
    - form, example, 191–192
    - information, 189
    - risk event audits, 189
    - risk management process, 189
    - risk response audits, 189
  - Risk Data Sheet, 119–121
    - elements, 120t
    - form
      - example, 121
      - usage, 15
    - information, 119
  - Risk event audits, 189
  - Risk Identification, information provision, 80
  - Risk Management Plan, 102–108
    - elements, 103t
    - form
      - example, 104–18
      - form, usage, 14
      - inclusion, 16
      - information, 2
        - source, 8, 102
      - usage, 114
    - Risk management process, 189
  - Risk Register, 109–111
    - documents, review, 111
    - elements, 110t

Risk Register (*continued*)

- form
  - example, 111
  - usage, 14
- information
  - provision, 109, 112
  - source, 8, 109
  - usage, 36, 40, 59, 71, 102
- Risk response audits, 189
- Risk tolerance, indication, 119
- Roles and Responsibilities, 93–95
  - elements, 93t
  - form
    - example, 94–95
    - usage, 14
  - information source, 93
  - Responsibility Assignment Matrix, responsibility, 93
  - section, 96

**S**

- Schedule Baseline, information provision, 43, 59
- Schedule Management Plan, 43–45
  - elements, 44t
  - form
    - example, 45
    - usage, 14
  - inclusion, 16
  - information, 2
  - provision, 43, 48
- Schedule performance, 193
- Schedule performance index (SPI), 186
- Schedule variance (SV), 182, 186
- Scope Baseline
  - information provision, 27, 48
  - Work Breakdown Structure (WBS)
    - Dictionary, relationship, 40
    - relationship, 38
- Scope Management Plan, 20–22
  - elements, 20t
  - form
    - example, 21–22
    - usage, 14
  - inclusion, 16
  - information, 2
- Scope performance, 193
- Scope Statement, information source, 20
- Scope variance, inclusion, 182
- Sequence Activities, process, 13
- Source Selection Criteria, 127
  - elements, 127t
  - evaluation criteria, 127

- form
    - usage, 15
    - example, 128
    - process, 128
  - Staff acquisition/release, 96
  - Staffing Management Plan, 96
  - Stakeholder Analysis Matrix, 11
    - form
      - example, 12
      - usage, 1
    - Stakeholder Register, relationship, 8
    - usage, 11
  - Stakeholder Management Plan, 129–131
    - form
      - example, 130–131
      - usage, 15
    - inclusion, 16
    - information source/provision, 129
    - Plan Stakeholder Management Plan, elements, 129t
  - Stakeholder Register, 8–10
    - elements, 9t
    - form
      - example, 10
      - usage, 1
    - information, 2
    - source, 8, 23
    - people/organizations identification, 8
  - Start dates, display, 65
  - Start-to-finish (SF), network diagram
    - relationship, 53
  - Start-to-start (SS), network diagram
    - relationship, 53
  - Subprojects, 38
- T**
- Team Directory, 136, 155–156
    - components, 155
    - elements, 155t
    - form, example, 156
  - Team Member Performance Appraisal, 136, 165–169
    - contents, 165
    - elements, 165t–166t
    - form, example, 167–169
    - interpersonal competency, 165
    - technical performance, 165
  - Team Member Status Report, 135, 137–142
    - elements, 137t–138t
    - form, example, 139–142
    - information, 137
      - compilation, 175

Team Operating Agreement, 136, 157–159  
 contents, 157  
 elements, 157t  
 form, example, 158–159

Team Performance Assessment, 136, 160–164  
 contents, 160  
 elements, 160t–161t  
 form, example, 162–164  
 interpersonal competency, 160  
 team characteristics, 160  
 technical performance, 160

Three-point estimates, 59, 73  
 Beta Distribution, elements, 62t–63t  
 elements, 74t  
 usage, 61

To complete performance index (TCPI), 186

Training requirements, 96

## V

Variance Analysis, 174, 182–185  
 cost variance, 182  
 elements, 182t–183t  
 form, example, 184–185  
 information, 182  
 quality variance, 182  
 schedule variance, 182  
 scope variance, inclusion, 182

Vendor management, 211  
 Vendor performance analysis, 203  
 Vendor performance audit, 199–200

## W

Work Breakdown Structure (WBS), 38–39  
 elements, 38t  
 form  
 example, 39  
 usage, 14  
 identifier, display, 65  
 information  
 provision, 33, 36  
 source, 20, 38  
 options, 38  
 Scope Baseline, relationship, 38

Work Breakdown Structure (WBS) Dictionary,  
 40–42  
 elements, 41t  
 form  
 example, 42  
 usage, 14  
 information, 40  
 source, 20, 40  
 Scope Baseline, relationship, 40

Work Performance Data, information, 197

